

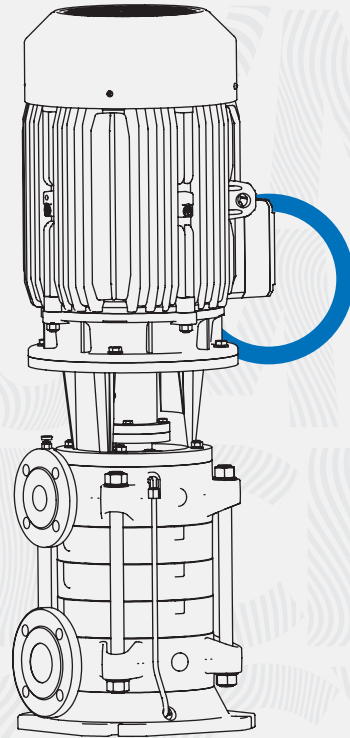

# ARS-D Series

**Vertical Multi Stage Centrifugal Pump**

Dikey Çok Kademeli Santrifüj Pompa



08.2019 - v4



[www.sempapompa.com](http://www.sempapompa.com)



power **traction** thrust



I'M  
PUMP  
TECH  
NOLOGY

## GENERAL INFORMATION

Discharge Flange	DN 32 - DN 150
Capacity	180 m <sup>3</sup> /h
Head	450 m
Frequency	Three-phase 50 Hz - 60 Hz*
Temperature of Pumped Liquid	From -25 °C to + 140 °C
Maximum Operating Pressure	25 bar (63 bar)*

Depending on the type of liquid, operating temperature and pressure. The pump material changes. Please contact our company for detailed information.

## Transferable Liquids

- Clean or slightly dirty, non-abrasive, low-viscosity fluids.

## Shaft Sealing

- Depending on request or requirement, pumps with soft packing or mechanical seals can be supplied.

## Applications

Water Treatment and Pressurization	Power Plants
Heating, Ventilating and Air Conditioning	Oil Industry
Agricultural Irrigation and Drainage	Chemical Industry
Food and Beverage Industry	Mining
Iron and Steel Industry	Fire Fighting
Building System	

## Design Features

- Centrifugal pumps with vertical shaft, split body, diffuser, multistage, closed impeller.
- 8 models from DN 32 to DN 150 discharge flange diameter.
- Suction flanges according to EN 1092 - 2 / PN 16 and discharge flanges to EN 1092 - 2 / PN 40 (PN 63). (flanges in pumps with stainless steel body material according to EN 1092-1 standard pressure class.)
- ARS-D and ARS-DY pumps are used with high efficiency electric motors according to IEC size.
- Pump and motor shafts are connected to each other with rigid coupling.
- All impellers are balanced dynamically or statically in accordance with ISO 1940 class 6.3.
- Axial force is balanced by impeller balancing holes system.
- The direction of rotation is counterclockwise when viewed from the motor side.
- In ARS-D and ARS-DY type pumps, "grease lubricated" bearings are used as standard. The plain bearings used on the underside of the pumps are lubricated with the pressed liquid.

## Pump Code

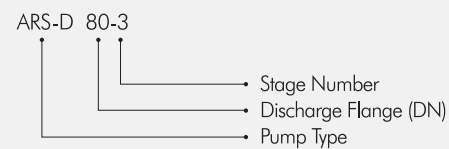

## GENEL BİLGİLER

Basma Flanşı	DN 32 - DN 150
Debi	180 m <sup>3</sup> /h
Basma Yüksekliği	450 m
Frekans	Üç Fazlı 50 Hz - 60 Hz*
Akışkan Sıcaklığı	-25 °C'den + 140 °C'ye kadar
Maksimum Çalışma Basıncı	25 bar (63 bar)*

Basılan sıvının cinsine, çalışma sıcaklığı ve basıncına bağlı olarak pompa malzemesi değişir. Ayrıntılı bilgi için firmamıza başvurunuz.

## Basılabilen Sıvılar

- Temiz veya çok hafif kirli, aşındırıcı olmayan, düşük viskoziteli sıvılar.

## Mil Sızdırmazlığı

- Basılan sıvının cinsine ve çalışma şartlarına bağlı olarak mekanik salmastra veya yumuşak salmastra kullanılmaktadır.

## Kullanım Yerleri

Su Arıtımı ve Basınçlandırılması	Enerji Santralleri
Isıtma, Havalandırma ve İklimlendirme	Petrol Endüstrisi
Tarımsal Sulama ve Drenaj	Kimya Endüstrisi
Gıda ve İçecek Endüstrisi	Madencilik
Demir Çelik Endüstrisi	Yangın Söndürme
Bina Sistemleri	

## Tasarım Özellikleri

- Düşey millî, parçalı gövdeli, difüzörlü, çok kademeli, kapalı çarklı santrifüj pompalar.
- DN 32' den DN 150 basma flanş çapına kadar 8 model.
- Emme flanşları TS EN 1092 - 2 / PN 16' ya, basma flanşları TS EN 1092 - 2 / PN 40 (PN 63)' e uygundur. (paslanmaz çelik gövde malzemeli pompalarda flanşlar TS EN 1092 - 1 standardı ilgili basınç sınıfına uygundur.)
- ARS-D pompalar IEC yapı büyüklüklerine uygun yüksek verimlilik sınıfında elektrik motorları ile kullanılır.
- Pompa ve motor milleri birbirlerine rijit kaplin ile bağlanır.
- Bütün çarklar ISO 1940 sınıf 6.3' e uygun dinamik veya statik olarak dengelenir.
- Eksenel kuvvet çark dengeleme delikleri sistemi ile dengelenmektedir.
- Dönme yönü motor tarafından bakılınca saat yönünün tersindedir.
- ARS-D tipi pompalarda standart olarak "gres yağlı" rulman kullanılmaktadır. Pompaların alt tarafında kullanılan kaymalı yataklar ise basılan sıvı ile yağlanmaktadır.

## Pompa Kodu



## MATERIAL OPTIONS

Part List	0.6025	0.7040	1.7043	1.0619	1.4308	1.4309	1.4408	1.4409	1.4500	1.4517	1.4469	1.4317	1.4008	2.1050.01	2.0975.01	2.1096.01	1.0503	1.4021	1.4021+QT	1.4301	1.4404	1.4460	1.4462	Tungsten Carbide	Parça Listesi	
Suction Body	●	○	○	○	○	○	○	○	○	○	○	○	○	○	○	○	○	○	○	○	○	○	○	○	○	Emme Gövdesi
Discharge Body	●	○	○	○	○	○	○	○	○	○	○	○	○	○	○	○	○	○	○	○	○	○	○	○	○	Basma Gövdesi
Stage Body	●	○	○	○	○	○	○	○	○	○	○	○	○	○	○	○	○	○	○	○	○	○	○	○	○	Kademe Gövdesi
Diffuser	●	○	○	○	○	○	○	○	○	○	○	○	○	○	○	○	○	○	○	○	○	○	○	○	○	Difüzör
Impeller	●	○	○	○	○	○	○	○	○	○	○	○	○	○	○	○	○	○	○	○	○	○	○	○	○	Çark
Shaft																		●	○	○	○	○	○	○	○	Pompa Mili
Wear Ring	○	○	○	○	○	○	○	○	○	○	○	○	○	○	○	○	○	○	○	○	○	○	○	○	○	Aşınma Halkası
Shaft Sleeve																		●	○	○	○	○	○	○	○	Ara Burç
Seal Sleeve																		●	○	○	○	○	○	○	○	Salmastra Burcu
Stage Sleeve																		●	○	○	○	○	○	○	○	Kademe Burcu
Bearing Bush																								○	○	Kaymalı Yatak
Mechanical Seal (*)																										Mekanik Salmastra (*)

(\*) Options: Different brand and type mechanical seal can be use can according to customer request.

(\*) Seçenekler: Alıcının isteğine veya çalışma şartlarına bağlı olarak değişik tip ve markalarda mekanik salmastra kullanılabilir.

- Standard Manufacturing
- Optional

- Standart İmalat
- İsteğe Bağlı

## DESCRIPTIONS

DIN

EN

AISI/SAE/ASTM

## TANIM

Material	DIN	EN	AISI/SAE/ASTM	TANIM
Cast Iron	0.6025	EN-GJL-250 (GG 25)	A 48 Class 40-B	Pik Döküm
Ductile Iron Casting	0.7040	EN-GJS-400-15-LT (GGG 40)	A 536 60-40-18	Sfero Döküm
Ductile Iron Casting	0.7043	EN-GJS-400-18-LT (GGG 40.3)	A 536 60-40-18	Sfero Döküm
Steel Casting	1.0619	GP 240 GHGS-C25	A216 WCB	Çelik Döküm
Chrome Nickel Steel Casting	1.4308	G-X5 Cr Ni 19-10	A 351 CF8	Krom Nikelli Çelik Döküm
Chrome Nickel Steel Casting (Low Carbon)	1.4309	G-X2 Cr Ni 19-11	A 351 CF3	Krom Nikelli Çelik Döküm (D. K.)
Chrome Nickel Molybdenum Steel Casting	1.4408	G-X5 Cr Ni Mo 19-11-2	A 351 CF8M	Krom Nikel Molibdenli Çelik Döküm
Chrome Nickel Molybdenum Steel Casting (L.C.)	1.4409	G-X2 Cr Ni Mo 19-11-2	A 351 CF3M	Krom Nikel Molibdenli Çelik Döküm (D.K.)
Austenitic Steel Casting	1.4500	G-X7 Cr Ni Mo Cu N 25-20	A 351 CN7M	Östenitik Çelik Döküm
Austenitic - Ferritic Steel Casting (Dublex)	1.4517	G-X2 Cr Ni Mo Cu N 25-6-3-3	A 890 CD4MCuN	Östenitik-ferritik Çelik Döküm (D.)
Austenitic - Ferritic Steel Casting (S.D.)	1.4469	G-X2 Cr Ni Mo N 26-7-4	A 890 CE3MN	Östenitik-ferritik Çelik Döküm (S.D.)
Martensitic Stainless Steel Casting	1.4317	G-X4 Cr Ni 13-4	A 352 CA6NM	Martenzitik Paslanmaz Çelik Döküm
Martensitic Stainless Steel Casting	1.4008	G-X7 Cr Ni Mo 12-1	A 217 CA15	Martenzitik Paslanmaz Çelik Döküm
Bronze Casting (Tinned)	2.1050.01	G-Cu Sn 10	B 427 C90700	Bronz Döküm (Kalaylı)
Bronze Casting (Nickel Alloy)	2.0975.01	G-Cu Al10 Ni	B 148 C95500	Bronz Döküm (Nikel Alaşımı)
Bronze Casting (Leaded)	2.1096.01	G-Cu Sn 5 Zn Pb	B 584 C83600	Bronz Döküm (Kurşunlu)
Carbon Steel	1.0503	C 45	AISI 1045	Karbonlu Çelik
Chromium Steel	1.4021	X20 Cr13	A 276 Type 420	Kromlu Çelik
Chrome Steel (Heat Treatment)	1.4021	X20 Cr13	A 276 Type 420+QT	Krom Nikel Çelik (Isıl İşlem)
Chrome Nickel Steel	1.4301	X5 Cr Ni 18-10	A 276 Type 304	Krom Nikel Çelik
Chrome Nickel Molybdenum Steel (L.C.)	1.4404	X2 Cr Ni Mo 17-12-2	A 276 Type 316L	Krom Nikel Molibdenli Çelik (D.K.)
Duplex (Austenitic-Ferritic) Steel	1.4460	X3 Cr Ni Mo N 27-5-2	AISI 329	Dubleks (Östenitik-Ferritik) Çelik
Duplex (Austenitic-Ferritic) Steel	1.4462	X2 Cr Ni Mo N 22-5-3	UNS S32205	Dubleks (Östenitik-Ferritik) Çelik



## SELECTION CHARTS

## SEÇİM EĞRİLERİ

1450 rpm / (d/d) (50 Hz)

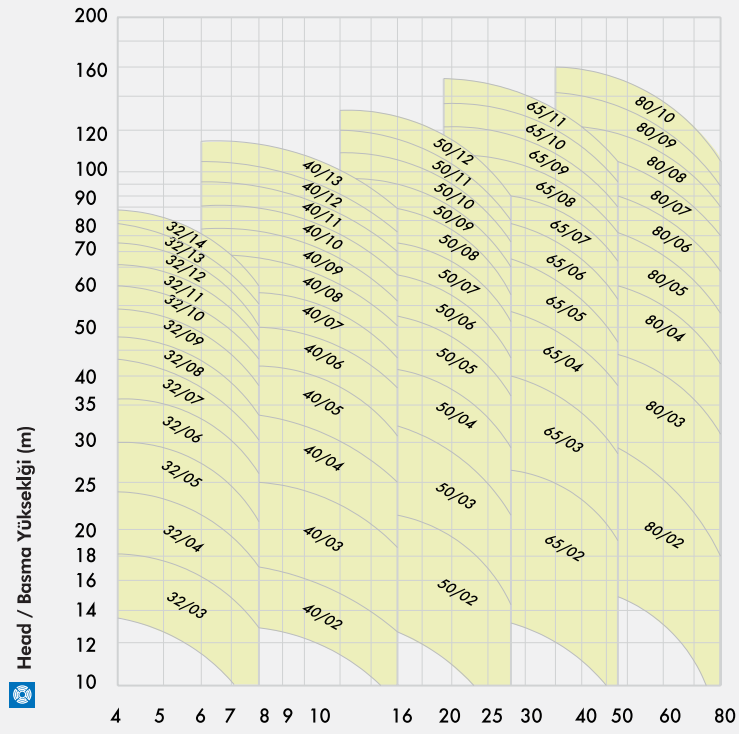

Capacity / Debi (m³/h)

2900 rpm / (d/d) (50 Hz)

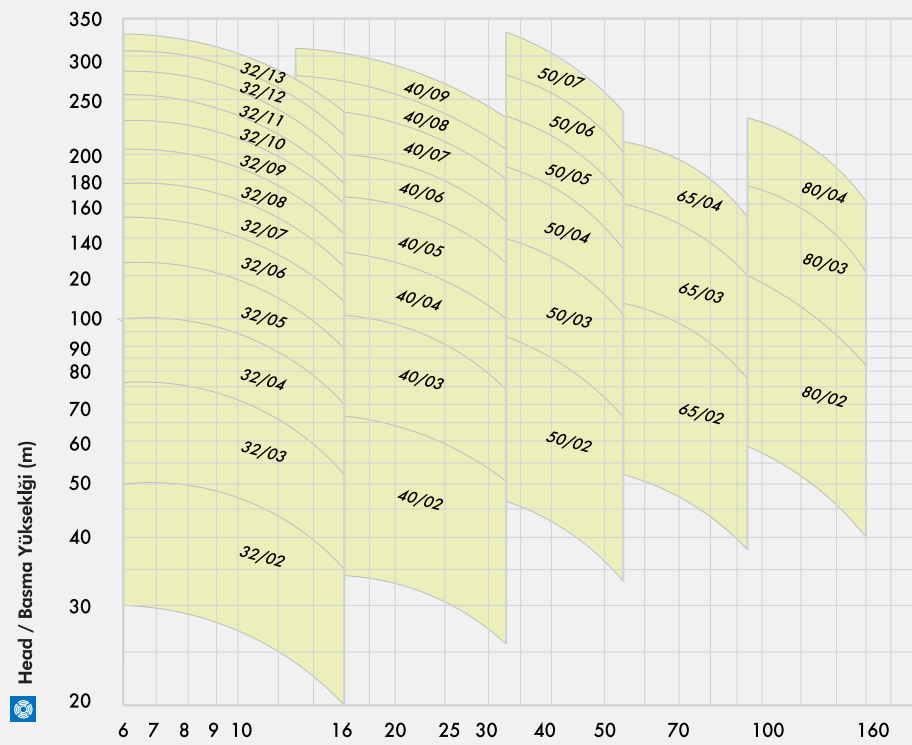

Capacity / Debi (m³/h)

For detailed curves, use our selection program.

Detay eğriler için seçim programımızı kullanınız.

## SELECTION CHARTS

## SEÇİM EĞRİLERİ

1750 rpm / (d/d) (60 Hz)

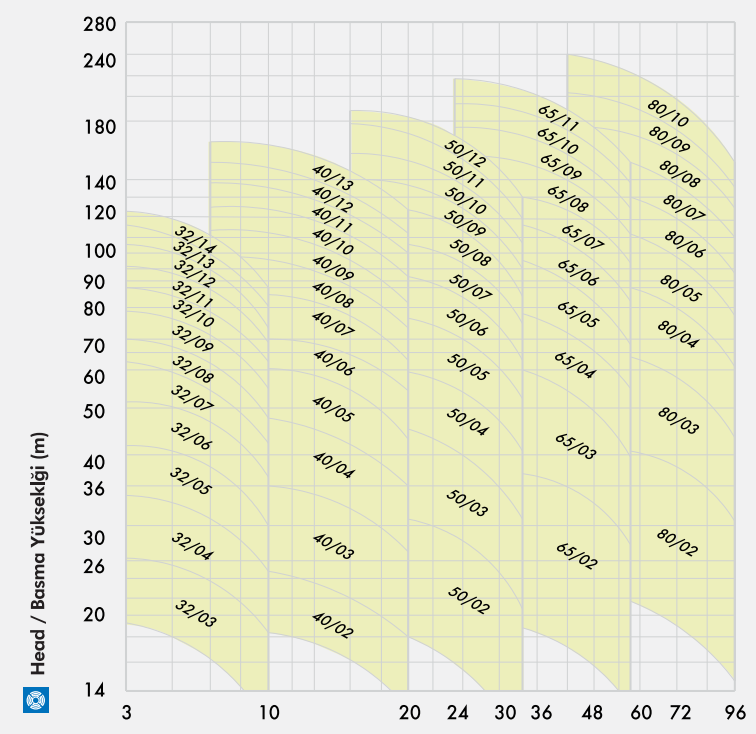

Capacity / Debi (m³/h)

3500 rpm / (d/d) (60 Hz)

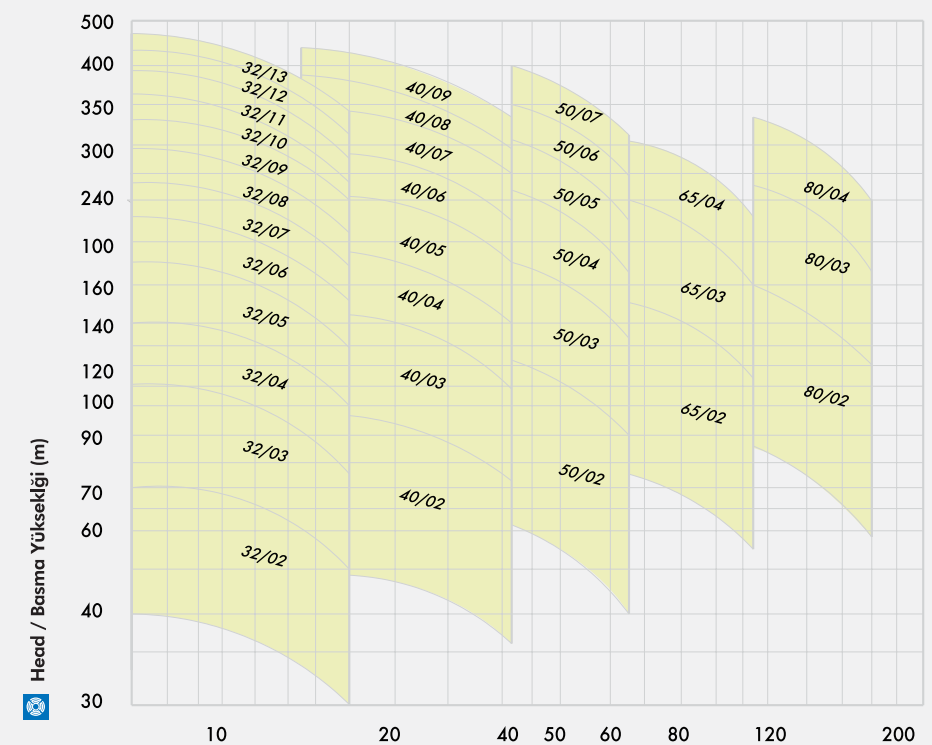

Capacity / Debi (m³/h)

For detailed curves, use our selection program.

Detay eğriler için seçim programımızı kullanınız.



## SECTIONAL VIEW

## KESİT RESİM

### ARS-D

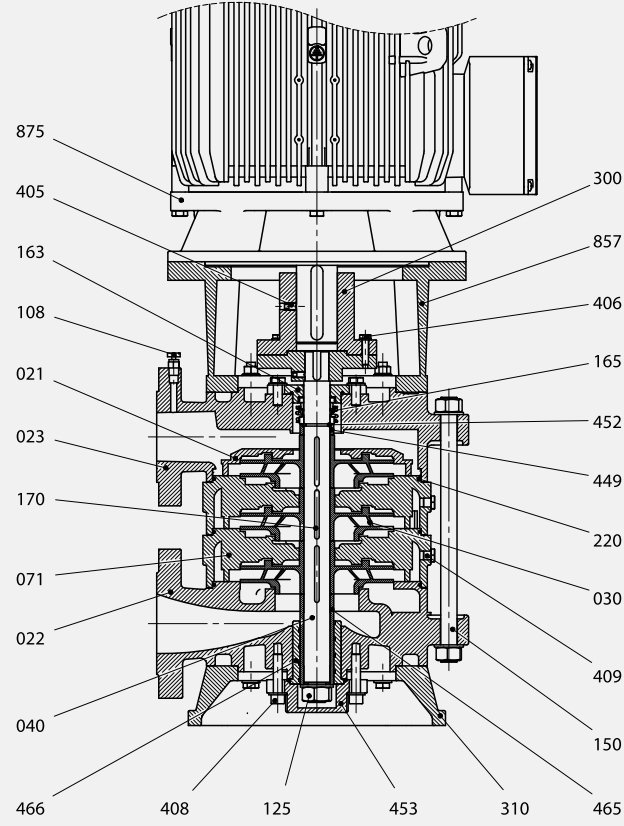

### Part List

### Parça Listesi

Part Name	Part No	Part Name	Part No
Discharge Diffuser	021	Basma Difüzörü	021
Suction Body	022	Emme Gövdesi	022
Discharge Body	023	Basma Gövdesi	023
Impeller	030	Çark	030
Shaft	040	Mil	040
Stage Body	071	Kademe Gövdesi	071
Air Purge	108	Hava Purjörü	108
Nut	125	Somun	125
Casing Tiebolt	150	Saplama	150
Mechanical Seal Cover	163	Mekanik Salmastra Kapağı	163
Mechanical Seal	165	Mekanik Salmastra	165
Pin	170	Kama	170
O-Ring	220	O-Ring	220
Coupling	300	Kaplin	300
Table	310	Tabla	310
Set Screw	405	Setskur	405
Bolt	406	DIN 933 Tam Paso Cıvata	406
Bolt	408	DIN 912 İmbus Cıvata	408
Bolt	409	BSP Cıvata	409
Seal Setting Sleeve	449	Salmastra Mesafe Burcu	449
Seal Sleeve Locker	452	Salmastra Burc Kilidi	452
Suction Housing Cover	453	Emme Yatak Kapağı	453
Suction Housing Sleeve	465	Emme Yatak Burcu	465
Suction Housing	466	Emme Yatağı	466
Motor Support Foot	857	Motor Taşıyıcı	857
Electric Motor	875	Elektrik Motoru	875

## PUMP DIMENSIONS

## POMPA ÖLÇÜLERİ

### ARS-D / 3000 rpm / (d/d)

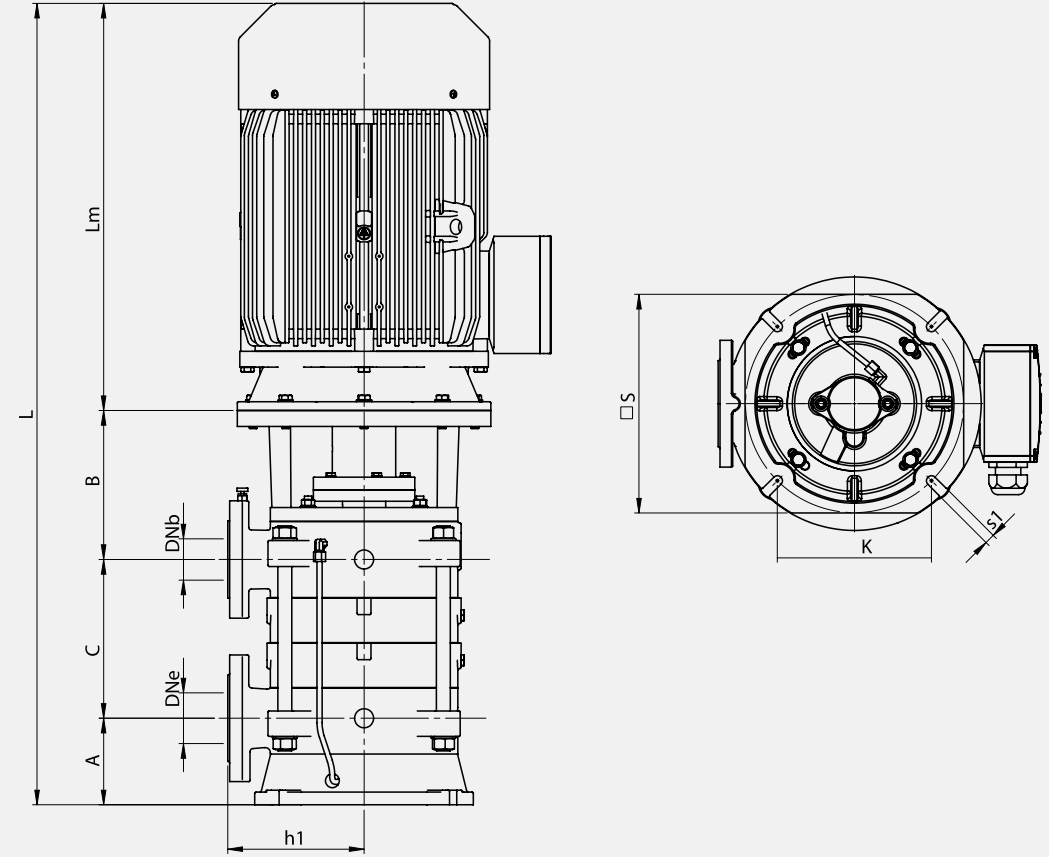

Pump Type Pompa Tipi	Frame Gövde	Dimensions / Ölçüler (mm)										"C" Dimensions By Stage (mm) Kademe Sayısına Göre "C" Ölçüsü						
		IEC	DN <sub>e</sub>	DN <sub>b</sub>	A	B	L <sub>m</sub>	L	h <sub>1</sub>	S	K	s <sub>1</sub>	2	3	4	5	6	7
ARS-D 32	100 L	40	32	111	158	-	L <sub>m</sub> +381	152	295	205	15	112	155	198	241	284	-	-
ARS-D 32	112 M	40	32	111	158	-	L <sub>m</sub> +424	152	295	205	15	112	155	198	241	284	-	-
ARS-D 32	132 S	40	32	111	183	-	L <sub>m</sub> +492	152	295	205	15	112	155	198	241	284	-	-
ARS-D 32	132 S	40	32	111	183	-	L <sub>m</sub> +535	152	295	205	15	112	155	198	241	284	-	-
ARS-D 32	160 M	40	32	111	213	-	L <sub>m</sub> +608	152	295	205	15	112	155	198	241	284	-	-
ARS-D 40	132 S	50	40	106	189	-	L <sub>m</sub> +428	175	300	209	18	133	188	243	298	-	-	-
ARS-D 40	160 M	50	40	106	222	-	L <sub>m</sub> +516	175	300	209	18	133	188	243	298	-	-	-
ARS-D 40	160 M	50	40	106	222	-	L <sub>m</sub> +571	175	300	209	18	133	188	243	298	-	-	-
ARS-D 40	160 L	50	40	106	222	-	L <sub>m</sub> +626	175	300	209	18	133	188	243	298	-	-	-
ARS-D 50	160 M	65	50	117	231	-	L <sub>m</sub> +500	190	347	243	18	152	214	276	-	-	-	-
ARS-D 50	160 L	65	50	117	231	-	L <sub>m</sub> +562	190	347	243	18	152	214	276	-	-	-	-
ARS-D 50	180 M	65	50	117	231	-	L <sub>m</sub> +562	190	347	243	18	152	214	276	-	-	-	-
ARS-D 50	180 M	65	50	117	231	-	L <sub>m</sub> +624	190	347	243	18	152	214	276	-	-	-	-
ARS-D 50	200 L	65	50	117	231	-	L <sub>m</sub> +624	190	347	243	18	152	214	276	-	-	-	-



## PUMP DIMENSIONS

## POMPA ÖLÇÜLERİ

### ARS-D / 3000 rpm / (d/d)

Pump Type Pompa Tipi	Frame Gövde	Dimensions / Ölçüler (mm)										"C" Dimensions By Stage (mm) Kademe Sayısına Göre "C" Ölçüsü						
		IEC	DNe	DNb	A	B	Lm	L	h1	S	K	s1	2	3	4	5	6	7
ARS-D 65	180 M	80	65	137	235	-	Lm+551	215	345	243	16	180	251	-	-	-	-	
ARS-D 65	200 L	80	65	137	235	-	Lm+551	215	345	243	16	180	251	-	-	-	-	
ARS-D 65	200 L	80	65	137	235	-	Lm+622	215	345	243	16	180	251	-	-	-	-	
ARS-D 65	225 M	80	65	137	235	-	Lm+622	215	345	243	16	180	251	-	-	-	-	
ARS-D 80	225 M	100	80	145	236	-	Lm+574	265	450	355	25	193	276	-	-	-	-	
ARS-D 80	250 M	100	80	145	266	-	Lm+604	265	450	355	25	193	276	-	-	-	-	
ARS-D 80	280 M	100	80	145	266	-	Lm+687	265	450	355	25	193	276	-	-	-	-	
ARS-D 80	280 M	100	80	145	266	-	Lm+687	265	450	355	25	193	276	-	-	-	-	

○ Please contact for 3600 rpm dimensions. Dimensions can be change according to motor brand.

3600 d/d ölçüleri için iletişime geçiniz. Motor markasına göre boyutlar değişebilir.

Shaft End Dimensions / Mil Ucu Ölçüleri (mm)				
Pump Type Pompa Tipi	d	L1	t	u
32	24	35	28	8
40	24	35	28	8
50	28	35	31	8
65	32	40	35	10
80	38	40	41	10

## SECTIONAL VIEW

## KESİT RESİMİ

### ARS-DY

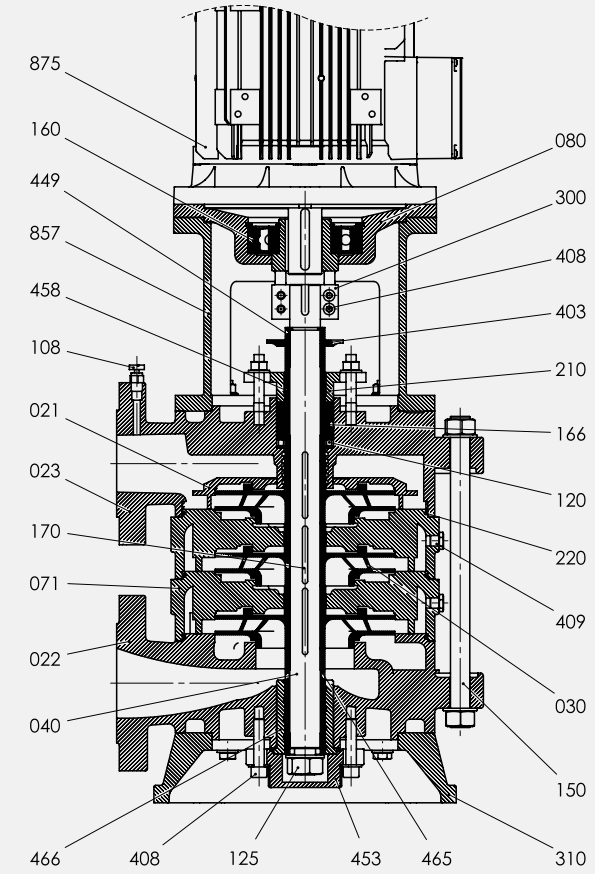

### Part List

### Parça Listesi

Discharge Diffuser	021	Basma Difüzörü
Suction Body	022	Emme Gövdesi
Discharge Body	023	Basma Gövdesi
Impeller	030	Çark
Shaft	040	Mil
Stage Body	071	Kademe Gövdesi
Bearing Housing	080	Rulman Yatağı
Air Purge	108	Hava Purjörü
Nut	120	Sulama Halkısı
Nut	125	Somun
Casing Tiebolt	150	Saplama
Bearing	160	Rulman
Soft Packing	166	Yumuşak Salmastra
Pin	170	Kama
Connection Support	210	Salmastra Baskısı
O-Ring	220	O-Ring
Coupling	300	Kaplin
Table	310	Tabla
Throw Protection	403	Su Sıçratma Diski
Bolt	408	DIN 912 Yarım Paso Cıvata
Bolt	409	BSP Cıvata
Seal Setting Sleeve	449	Salmastra Mesafe Burcu
Suction Housing Cover	453	Emme Yatak Kapağı
Seal Sleeve	458	Salmastra Burcu
Suction Housing Sleeve	465	Emme Yatak Burcu
Suction Housing	466	Emme Yatağı
Motor Support Foot	857	Motor Taşıyıcı
Electric Motor	875	Elektrik Motoru



## PUMP DIMENSIONS

## POMPA ÖLÇÜLERİ

### ARS-DY / 1500 rpm / (d/d)

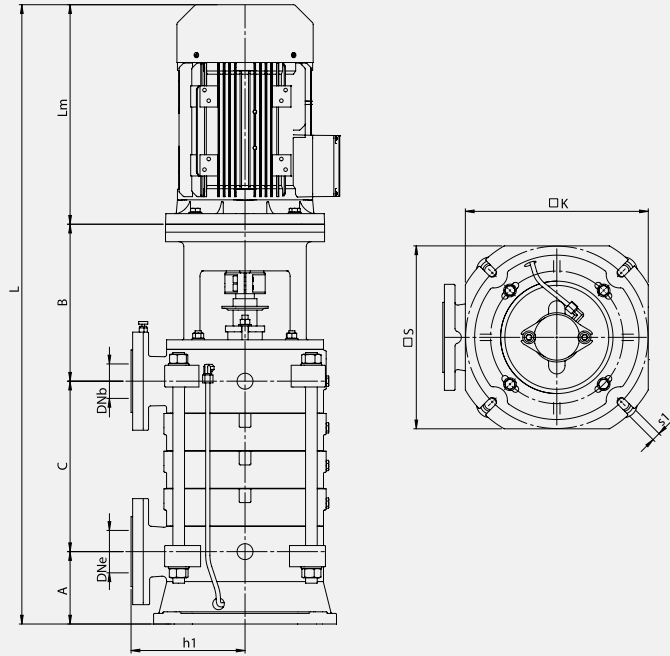

Pump Type Pompa Tipi	Frame Gövde	Dimensions / Ölçüler (mm)									"C" Dimensions By Stage (mm) / Kademe Sayısına Göre "C" Ölçüsü													
		IEC	DN <sub>e</sub>	DN <sub>b</sub>	A	B	L	h <sub>1</sub>	S	K	s <sub>1</sub>	2	3	4	5	6	7	8	9	10	11	12	13	14
ARS-DY 32	80 M	40	32	111	236	581+C	152	295	205	15		155	198	241	284	327	370	413	456	499	542	585	628	
ARS-DY 32	90 S	40	32	111	236	622+C	152	295	205	15		155	198	241	284	327	370	413	456	499	542	585	628	
ARS-DY 32	100 L	40	32	111	241	661+C	152	295	205	15		155	198	241	284	327	370	413	456	499	542	585	628	
ARS-DY 40	90 S	50	40	106	243	568+C	175	300	209	18	133	188	243	298	353	408	463	518	573	628	683	738	-	
ARS-DY 40	100 L	50	40	106	248	663+C	175	300	209	18	133	188	243	298	353	408	463	518	573	628	683	738	-	
ARS-DY 40	112 M	50	40	106	248	694+C	175	300	209	18	133	188	243	298	353	408	463	518	573	628	683	738	-	
ARS-DY 40	132 S	50	40	106	248	788+C	175	300	209	18	133	188	243	298	353	408	463	518	573	628	683	738	-	
ARS-DY 50	100 L	65	50	117	257	620+C	190	347	243	18	152	214	276	338	400	462	524	586	648	710	772	-	-	
ARS-DY 50	112 M	65	50	117	257	703+C	190	347	243	18	152	214	276	338	400	462	524	586	648	710	772	-	-	
ARS-DY 50	132 S-M	65	50	117	277	808+C	190	347	243	18	152	214	276	338	400	462	524	586	648	710	772	-	-	
ARS-DY 50	160 M	65	50	117	307	916+C	190	347	243	18	152	214	276	338	400	462	524	586	648	710	772	-	-	
ARS-DY 65	112 M	80	65	137	276	845+C	215	345	243	16	180	251	322	393	464	535	606	677	748	819	-	-	-	
ARS-DY 65	132 M	80	65	137	296	844+C	215	345	243	16	180	251	322	393	464	535	606	677	748	819	-	-	-	
ARS-DY 65	160 M	80	65	137	326	952+C	215	345	243	16	180	251	322	393	464	535	606	677	748	819	-	-	-	
ARS-DY 65	160 L	80	65	137	326	956+C	215	345	243	16	180	251	322	393	464	535	606	677	748	819	-	-	-	
ARS-DY 65	180 M	80	65	137	326	1034+C	215	345	243	16	180	251	322	393	464	535	606	677	748	819	-	-	-	
ARS-DY 65	180 L	80	65	137	326	1036+C	215	345	243	16	180	251	322	393	464	535	606	677	748	819	-	-	-	
ARS-DY 80	160 M	100	80	145	326	963+C	265	450	355	25	193	276	359	442	525	608	691	774	857	940	-	-	-	
ARS-DY 80	160 L	100	80	145	326	964+C	265	450	355	25	193	276	359	442	525	608	691	774	857	940	-	-	-	
ARS-DY 80	180 M	100	80	145	326	1046+C	265	450	355	25	193	276	359	442	525	608	691	774	857	940	-	-	-	
ARS-DY 80	180 L	100	80	145	326	1046+C	265	450	355	25	193	276	359	442	525	608	691	774	857	940	-	-	-	
ARS-DY 80	200 L	100	80	145	326	1112+C	265	450	355	25	193	276	359	442	525	608	691	774	857	940	-	-	-	
ARS-DY 80	225 S	100	80	145	356	1187+C	265	450	355	25	193	276	359	442	525	608	691	774	857	940	-	-	-	

○ Please contact for 1800 rpm dimensions. Dimensions can be change according to motor brand.

1800 d/d ölçüleri için iletişime geçiniz. Motor markasına göre boyutlar değişebilir.

## PUMP DIMENSIONS

## POMPA ÖLÇÜLERİ

### ARS-DY / 3000 rpm / (d/d)

Pump Type Pompa Tipi	Frame Gövde	Dimensions / Ölçüler (mm)									"C" Dimensions By Stage (mm) / Kademe Sayısına Göre "C" Ölçüsü													
		IEC	DN <sub>e</sub>	DN <sub>b</sub>	A	B	L	h <sub>1</sub>	S	K	s <sub>1</sub>	2	3	4	5	6	7	8	9	10	11	12	13	14
ARS-DY 32	112 M	40	32	106	241	682+C	152	295	205	15	112	155	198	241	284	327	370	413	456	499	542	585	-	
ARS-DY 32	132 S	40	32	106	261	785+C	152	295	205	15	112	155	198	241	284	327	370	413	456	499	542	585	-	
ARS-DY 32	160 M	40	32	106	291	893+C	152	295	205	15	112	155	198	241	284	327	370	413	456	499	542	585	-	
ARS-DY 32	160 L	40	32	106	291	896+C	152	295	205	15	112	155	198	241	284	327	370	413	456	499	542	585	-	
ARS-DY 32	180 M	50	32	106	291	977+C	152	295	205	15	112	155	198	241	284	327	370	413	456	499	542	585	-	
ARS-DY 40	132 S	50	40	106	268	787+C	175	300	209	18	133	188	243	298	353	408	463	518	573	628	683	-	-	
ARS-DY 40	160 M	50	40	106	298	897+C	175	300	209	18	133	188	243	298	353	408	463	518	573	628	683	-	-	
ARS-DY 40	160 L	50	40	106	298	897+C	175	300	209	18	133	188	243	298	353	408	463	518	573	628	683	-	-	
ARS-DY 40	180 M	50	40	106	298	978+C	175	300	209	18	133	188	243	298	353	408	463	518	573	628	683	-	-	
ARS-DY 40	200 L	50	40	106	298	1045+C	175	300	209	18	133	188	243	298	353	408	463	518	573	628	683	-	-	
ARS-DY 40	255 M	50	40	106	298	1142+C	175	300	209	18	133	188	243	298	353	408	463	518	573	628	683	-	-	
ARS-DY 40	250 M	50	40	106	328	1185+C	175	300	209	18	133	188	243	298	353	408	463	518	573	628	683	-	-	

Pump Type Pompa Tipi	Frame Gövde	Dimensions / Ölçüler (mm)									"C" Dimensions By Stage (mm) / Kademe Sayısına Göre "C" Ölçüsü													
		IEC	DN <sub>e</sub>	DN <sub>b</sub>	A	B	L	h <sub>1</sub>	S	K	s <sub>1</sub>	2	3	4	5	6	7	8	9	10	11	12	13	14
ARS-DY 50	160 M	65	50	117	307	916+C	190	347	243	18	152	214	276	338	400	462	524	586	648	-	-	-	-	
ARS-DY 50	180 M	65	50	117	307	998+C	190	347	243	18	152	214	276	338	400	462	524	586	648	-	-	-	-	
ARS-DY 50	200 L	65	50	117	307	1054+C	190	347	243	18	152	214	276	338	400	462	524	586	648	-	-	-	-	
ARS-DY 50	225 M	65	50	117	307	1110+C	190	347	243	18	152	214	276	338	400	462	524	586	648	-	-	-	-	
ARS-DY 50	250 M	65	50	117	307	1205+C	190	347	243	18	152	214	276	338	400	462	524	586	648	-	-	-	-	
ARS-DY 50	280 M	65	50	117	307	1333+C	190	347	243	18	152	214	276	338	400	462	524	586	648	-	-	-	-	
ARS-DY 65	200 L	80	65	137	356	1100+C	215	345	243	16	180	251	322	393	464	535	-	-	-	-	-	-	-	
ARS-DY 65	250 M	80	65	137	356	1246+C	215	345	243	16	180	251	322	393	464	535	-	-	-	-	-	-	-	
ARS-DY 65	280 M	80	65	137	356	1378+C	215	345	243	16	180	251	322	393	464	535	-	-	-	-	-	-	-	
ARS-DY 65	315 S	80	65	137	356	1468+C	215	345	243	16	180	251	322	393	464	535	-	-	-	-	-	-	-	
ARS-DY 80	250 M	100	80	145	359	1258+C	265	450	355	25	193	276	359	-	-	-	-	-	-	-	-	-	-	
ARS-DY 80	280 M	100	80	145	359	1390+C	265	450	355	25	193	276	359	-	-	-	-	-	-	-	-	-	-	
ARS-DY 80	315 L	100	80	145	359	1481+C	265	450	355	25	193	276	359	-	-	-	-	-	-	-	-	-	-	

○ Please contact for 3600 rpm dimensions. Dimensions can be change according to motor brand.

3600 d/d ölçüleri için iletişime geçiniz. Motor markasına göre boyutlar değişebilir.

Shaft End Dimensions / Mil Ucu Ölçüleri (mm)				
Pump Type Pompa Tipi	d	L1	t	u
32	24	35	28	8
40	24	35	28	8
50	28	35	31	8
65	32	40	35	10
80	38	40	41	10



## FLANGE DIMENSIONS

Pump Type Pompa Tipi	Suction / Emme (PN 16)						Discharge / Basma (PN 40)					
	DNe	Df	k	s	n	bf	DNb	Df	k	s	n	s
25	50	165	125	18	4	20	32	165	100	18	4	18
32	65	185	145	18	4	20	40	185	110	18	4	18
40	65	185	145	18	4	20	50	185	125	18	4	20
50	80	200	160	18	8	22	65	200	145	18	4	20
65	100	220	180	18	8	24	80	220	160	18	8	22
80	125	250	210	18	8	26	100	250	180	18	8	24
100	150	285	240	23	8	26	125	285	210	18	8	26
125	200	340	295	23	12	30	150	340	240	23	8	26
150	250	405	355	27	12	31	200	405	295	23	12	32

TS EN 1092-2  "n" Number of Holes / Delik Sayısı

## FLANŞ ÖLÇÜLERİ

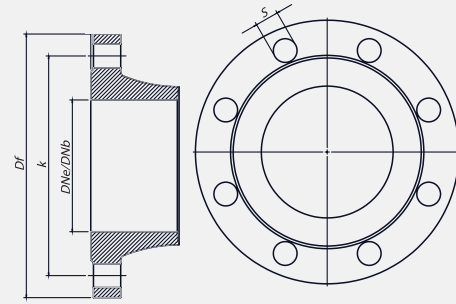

## FLANGE POSITIONS

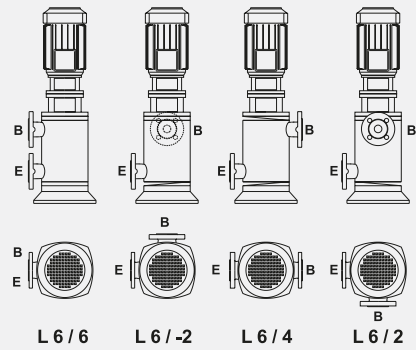

Direction of rotation viewed from driver end.  
L : Left

Attention: In the absence of specific request, pumps are supplied with the following nozzle arrangement:  
 . L 6/4 : up to 2 stages  
 . L 6/6 : 3 or more stages

## FLANŞ KONUMLARI

Motor tarafından bakıldığında dönme yönü.   
L : Sol

Dikkat: Özel istek olmadıkça pompa flanşları standart olarak aşağıdaki gibi düzenlenir:  
 . L 6/4 : 2 kademeye kadar  
 . L 6/6 : 3 ve daha fazla kademe

**48 YIL**  
**48 Years**

48 Yıldır Yanınızdayız  
We Have Been With You For 48 Years

**DENEY**  
**Testing**

Her Ürün İle Test Raporu Teslimi  
Supply Testing Report For Each Pump

**Sfero Döküm**  
Ductile Cast Iron

**Çelik**  
Steel

**Bronz**  
Bronze

**Pik Döküm**  
Cast Iron

**Paslanmaz Çelik**  
Stainless Steel

**Duplex Çelik**  
Duplex Steel

**KALITE KONTROL**  
**Quality Control**

**İŞLEME**  
**Machining**

CNC - Hassas İşleme - Kalite Kontrol  
CNC - Sensitive Machining - Quality Control

**STOK**  
**Stock**

500.000 Kg İşlenmiş Parça  
500.000 Kg Machined Part

**DÖKÜM**  
**Casting**

**I'M**  
**TECH**  
NOLOGY







**SEMPA**

DPT SERIES

TKF SERIES

ARS SERIES

**ARS-D SERIES**

TKF-M SERIES

SP SERIES

TKF-KE SERIES

**STORE / MAĞAZA:**

Fevzi Çakmak Mh.10644 Sk. No:43-45 Karatay / Konya / Türkiye

Tel:+90.332 237 03 31 Fax:+90.332 235 43 64

Mail: info2@sempapompa.com

**FACTORY / FABRİKA:**

Büyük Kayaak Mh. K.O.S.B. Kuddusi Cd. 22. Sk. No:4 Selçuklu / Konya / Türkiye

Tel:+90.332 345 32 90 Fax:+90.332 345 32 95

Mail: info@sempapompa.com