

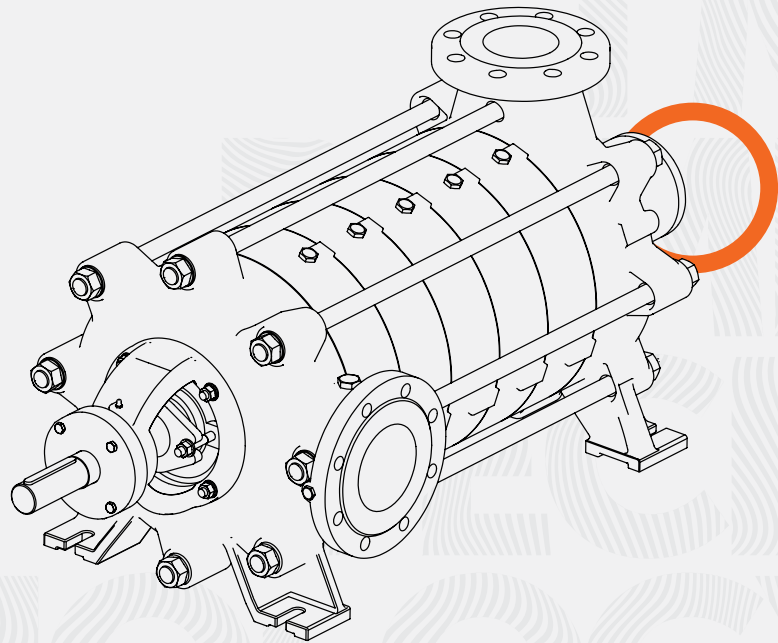

# ARS Series

**Horizontal Multi Stage Centrifugal Pump**

Yatay Çok Kademeli Santrifüj Pompa



08.2019 - v3

## GENERAL INFORMATION

Discharge Flange	DN 25 - DN 250
Capacity	1000 m <sup>3</sup> /h
Head	600 m
Frequency	Three-phase 50 Hz - 60 Hz*
Temperature of Pumped Liquid	From -25 °C to + 140 °C
Maximum Operating Pressure	25 bar (63 bar)*

Depending on the type of liquid, operating temperature and pressure. The pump material changes. Please contact our company for detailed information.

## Transferable Liquids

- Low-viscosity liquids that are non-abrasive, free of solid particles and fibers, clean or slightly contaminated.

## Shaft Sealing

- In standard production, it is used as soft packing up to 110 °C and soft packing together with refrigerated packing boxes between 110 °C and 140 °C.
- Mechanical seal pumps are also available upon request.

## Applications

Water Treatment and Pressurization	Power Plants
Heating Ventilating and Air Conditioning	Oil Industry
Agricultural Irrigation and Drainage	Chemical Industry
Food and Beverage Industry	Mining
Iron and Steel Industry	Marine
Building System	Fire Fighting

## Design Features

- Centrifugal pumps with horizontal shaft, split body, diffuser, multistage, closed impeller.
- 11 models from DN 25 to DN 250 discharge flange diameter.
- Suction flanges according EN 1092 - 2 / PN 16 and discharge flanges to EN 1092 - 2 / PN 40 (PN 63). (flanges in pumps with stainless steel body material according to EN 1092-1 standard pressure class.)
- In standard production, the suction flange is on the coupling side and on the right side, the discharge flange at the other end and top (R 4/2). If flange positions other than standard manufacture are required, this request must be specified at the time of order.
- All impellers are balanced dynamically or statically in accordance with ISO 1940 class 6.3.
- Axial force is balanced by impeller balancing holes system.
- The direction of rotation is clockwise when viewed from the motor side.
- ARS type pumps use "grease lubricated" bearings as standard.

## Pump Code

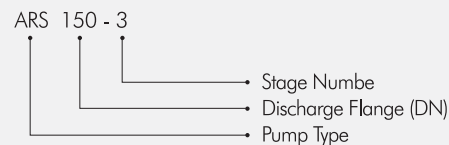

## GENEL BİLGİLER

Basma Flaşı	DN 25 - DN 250
Debi	1000 m <sup>3</sup> /h
Basma Yüksekliği	600 m
Frekans	Üç Fazlı 50 Hz - 60 Hz*
Akışkan Sıcaklığı	-25 °C'den + 140 °C'ye kadar
Maksimum Çalışma Basıncı	25 bar (63 bar)*

Basılan sıvının cinsine, çalışma sıcaklığı ve basıncına bağlı olarak pompa malzemesi değişir. Ayrıntılı bilgi için firmamıza başvurunuz.

## Basılabilen Sıvılar

- Aşındırıcı olmayan, içinde katı parçacıklar ve elyaf bulunmayan, temiz veya çok hafif kirlı, düşük viskoziteli sıvılar.

## Mil Sızdırmazlığı

- Standart imalatta 110 °C'ye kadar yumuşak salmastralı, 110 °C ile 140 °C arasında ise soğutmalı salmastra kutuları ile birlikte yumuşak salmastralı olarak kullanılmaktadır.
- İstek halinde mekanik salmastralı pompalar da kullanılmaktadır.

## Kullanım Yerleri

Su Arıtımı ve Basınçlandırılması	Enerji Santralleri
İstima, Havalandırma ve İklimlendirme	Petrol Endüstrisi
Tarımsal Sulama ve Drenaj	Kimya Endüstrisi
Gıda ve İçecek Endüstrisi	Madencilik
Demir Çelik Endüstrisi	Denizcilik
Bina Sistemleri	Yangın Söndürme

## Tasarım Özellikleri

- Yatay millı, parçalı gövdeli, difüzörlü, çok kademeli, kapalı çarklı santrifüj pompalar.
- DN 25'den DN 250 basma flaş çapına kadar 11 model.
- Emme flaşları TS EN 1092 - 2 / PN 16'ya, basma flaşları TS EN 1092 - 2 / PN 40 (PN 63)'e uygundur. (paslanmaz çelik gövde malzemeli pompalarda flaşlar TS EN 1092 - 1 standardı ilgili basınç sınıfına uygundur.)
- Standart imalatta emme flaşları kaplin tarafında ve sağ yanda, basma flaşları diğer uca ve üsttedir (R 4/2). Standart imalatın dışında flaş konumları istenirse, bu istek sipariş sırasında belirtilmelidir.
- Bütün çarklar ISO 1940 sınıf 6.3' e uygun dinamik veya statik olarak dengelenir.
- Eksenel kuvvet çark dengeleme delikleri sistemi ile dengelenmektedir.
- Dönme yönü motor tarafından bakılınca saat yönündedir.
- ARS tipi pompalarda standart olarak "gres yağlı" rulman kullanılmaktadır.

## Pompa Kodu

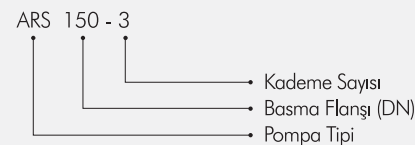

## MATERIAL OPTIONS

Part List	0.6025	0.7040	1.7043	1.0619	1.4308	1.4309	1.4408	1.4409	1.4500	1.4517	1.4469	1.4317	1.4008	2.1050.01	2.1050.01	2.1096.01	1.0503	1.4021	1.4021+QT	1.4301	1.4404	1.4460	1.4462	Parça Listesi	
Suction Body	●	○	○	○	○	○	○	○	○	○	○	○	○	○	○	○	○	○	○	○	○	○	○	○	Emme Gövdesi
Discharge Body	●	○	○	○	○	○	○	○	○	○	○	○	○	○	○	○	○	○	○	○	○	○	○	○	Basma Gövdesi
Stage Body	●	○	○	○	○	○	○	○	○	○	○	○	○	○	○	○	○	○	○	○	○	○	○	○	Kademe Gövdesi
Diffuser	●	○	○	○	○	○	○	○	○	○	○	○	○	○	○	○	○	○	○	○	○	○	○	○	Difüzör
Impeller	●	○	○	○	○	○	○	○	○	○	○	○	○	○	○	○	○	○	○	○	○	○	○	○	Çark
Shaft																		●	○	○	○	○	○	○	Pompa Mili
Bearing Box	●	○	○	○	○	○	○	○	○	○	○	○	○	○	○	○	○	○	○	○	○	○	○	○	Rulman Yatağı
Wear ring	○	○	○	○	○	○	○	○	○	○	○	○	○	○	○	○	○	○	○	○	○	○	○	○	Aşınma Halkası
Shaft Sleeve																		●	○	○	○	○	○	○	Ara Burç
Seal Sleeve																		●	○	○	○	○	○	○	Salmastra Burcu
Stage Sleeve																		●	○	○	○	○	○	○	Kademe Burcu
Mech. Seal (*)	EN 12756 / DIN 24250																						Mek. Salmastra (*)		

(\*) Options: Different brand and type mechanical seal can be use can according to customer request.

(\*) Seçenekler: Alıcının isteğine veya çalışma şartlarına bağlı olarak değişik tip ve markalarda mekanik salmastra kullanılabilir.

- Standard Manufacturing
- Optional

- Standart İmalat
- İsteğe Bağlı

## DESCRIPTIONS

	DIN	EN	AISI/SAE/ASTM	TANIM
Cast Iron	0.6025	EN-GJL-250 (GG 25)	A 48 Class 40-B	Pik Döküm
Ductile Iron Casting	0.7040	EN-GJS-400-18-LT (GGG 40)	A 536 60-40-18	Sfero Döküm
Ductile Iron Casting	0.7043	EN-GJS-400-18-LT (GGG 40.3)	A 536 60-40-18	Sfero Döküm
Steel Casting	1.0619	GP 240 GHGS-C25	A216 WCB	Çelik Döküm
Chrome Nickel Steel Casting	1.4308	G-X5 Cr Ni 19-10	A 351 CF8	Krom Nikelli Çelik Döküm
Chrome Nickel Steel Casting (Low Carbon)	1.4309	G-X2 Cr Ni 19-11	A 351 CF3	Krom Nikelli Çelik Döküm (D. K.)
Chrome Nickel Molybdenum Steel Casting	1.4408	G-X5 Cr Ni Mo 19-11-2	A 351 CF8M	Krom Nikel Molibdenli Çelik Döküm
Chrome Nickel Molybdenum Steel Casting (L.C.)	1.4409	G-X2 Cr Ni Mo 19-11-2	A 351 CF3M	Krom Nikel Molibdenli Çelik Döküm (D.K.)
Austenitic Steel Casting	1.4500	G-X7 Cr Ni Mo Cu N 25-6-3-3	A 351 CN7M	Östenitik Çelik Döküm
Austenitic - Ferritic Steel Casting (Duplex)	1.4517	G-X2 Cr Ni Mo Cu N 25-6-3-3	A 890 CD4MCuN	Östenitik-ferritik Çelik Döküm (D.)
Austenitic - Ferritic Steel Casting (S.D.)	1.4469	G-X2 Cr Ni Mo N 26-7-4	A 890 CE3MN	Östenitik-ferritik Çelik Döküm (S.D.)
Martensitic Stainless Steel Casting	1.4317	G-X4 Cr Ni 13-4	A 352 CA6NM	Martenzitik Paslanmaz Çelik Döküm
Martensitic Stainless Steel Casting	1.4008	G-X7 Cr Ni Mo 12-1	A 217 CA15	Martenzitik Paslanmaz Çelik Döküm
Bronze Casting (Tinned)	2.1050.01	G-Cu Sn 10	B 427 C90700	Bronz Döküm (Kalaylı)
Bronze Casting (Nickel Alloy)	2.0975.01	G-Cu Al10 Ni	B 148 C95500	Bronz Döküm (Nikel Alaşımı)
Bronze Casting (Leaded)	2.1096.01	G-Cu Sn 5 Zn Pb	B 584 C83600	Bronz Döküm (Kurşunlu)
Carbon Steel	1.0503	C 45	AISI 1045	Karbonlu Çelik
Chromium Steel	1.4021	X20 Cr13	A 276 Type 420	Kromlu Çelik
Chrome Steel (Heat Treatment)	1.4021	X20 Cr13	A 276 Type 420+QT	Krom Nikel Çelik (Isl İşlem)
Chrome Nickel Steel	1.4301	X5 Cr Ni 18-10	A 276 Type 304	Krom Nikel Çelik
Chrome Nickel Molybdenum Steel (L.C.)	1.4404	X2 Cr Ni Mo 17-12-2	A 276 Type 316L	Krom Nikel Molibdenli Çelik (D.K.)
Duplex (Austenitic-Ferritic) Steel	1.4460	X3 Cr Ni Mo N 27-5-2	AISI 329	Dubleks (Östenitik-Ferritik) Çelik
Duplex (Austenitic-Ferritic) Steel	1.4462	X2 Cr Ni Mo N 22-5-3	UNS S32205	Dubleks (Östenitik-Ferritik) Çelik



## SELECTION CHARTS

## SEÇİM EĞRİLERİ

1450 rpm / (d/d) (50 Hz)

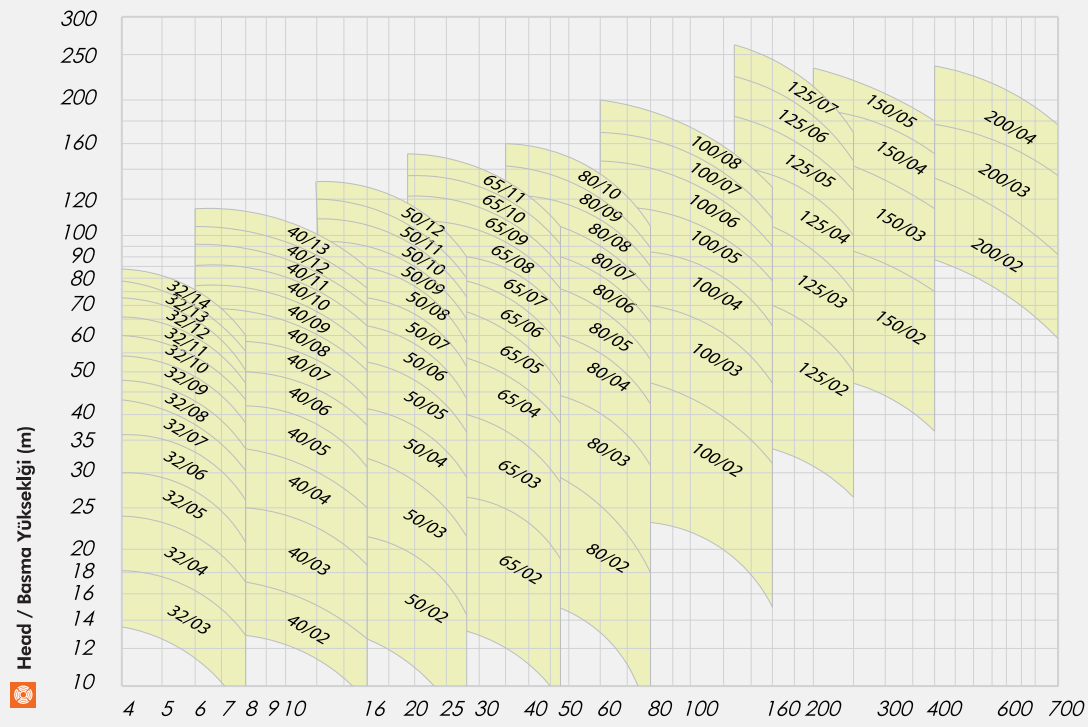

Capacity / Debi (m³/h)

2900 rpm / (d/d) (50 Hz)

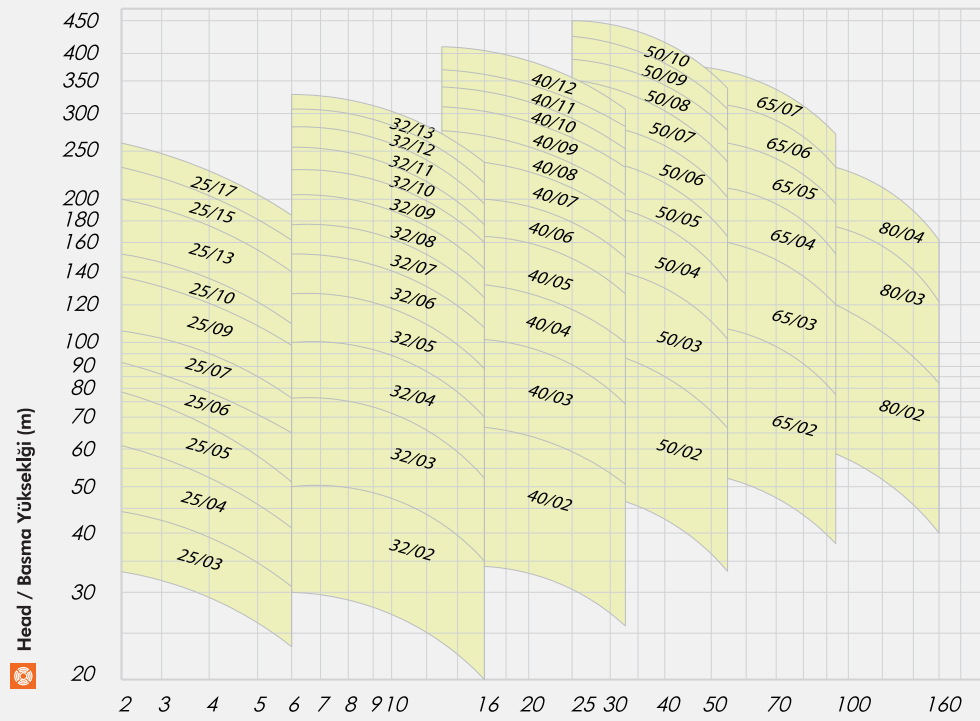

Capacity / Debi (m³/h)

For detailed curves, use our selection program.

Detay eğriler için seçim programımızı kullanınız.

## SELECTION CHARTS

## SEÇİM EĞRİLERİ

1750 rpm / (d/d) (60 Hz)

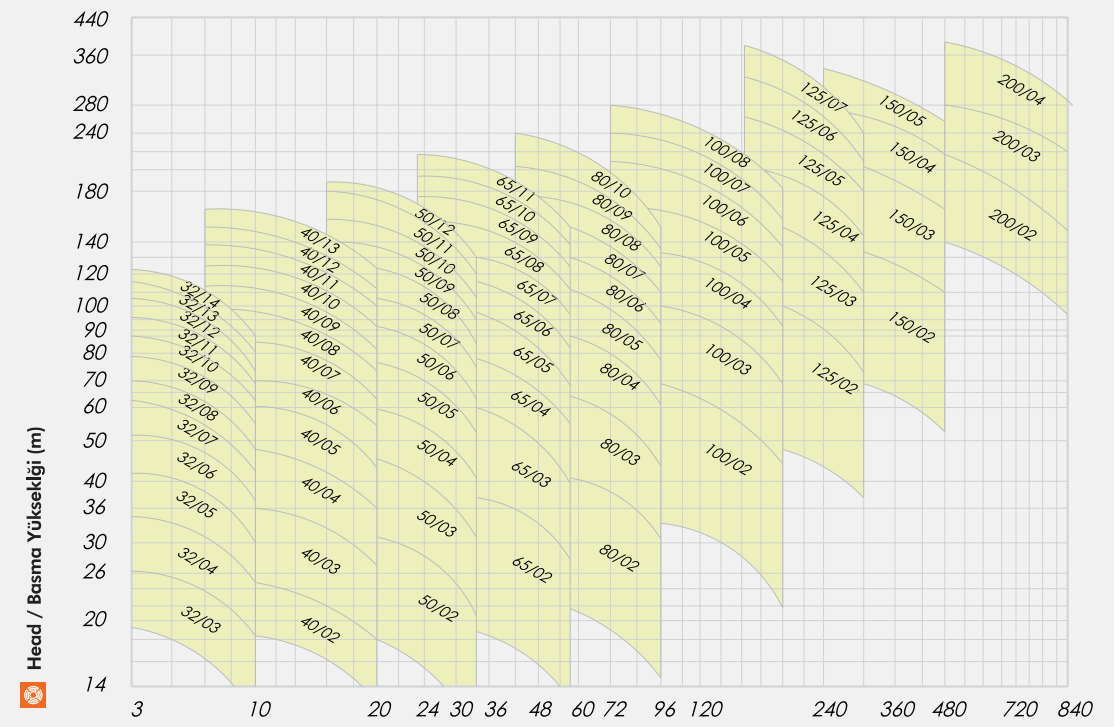

Capacity / Debi (m³/h)

3500 rpm / (d/d) (60 Hz)

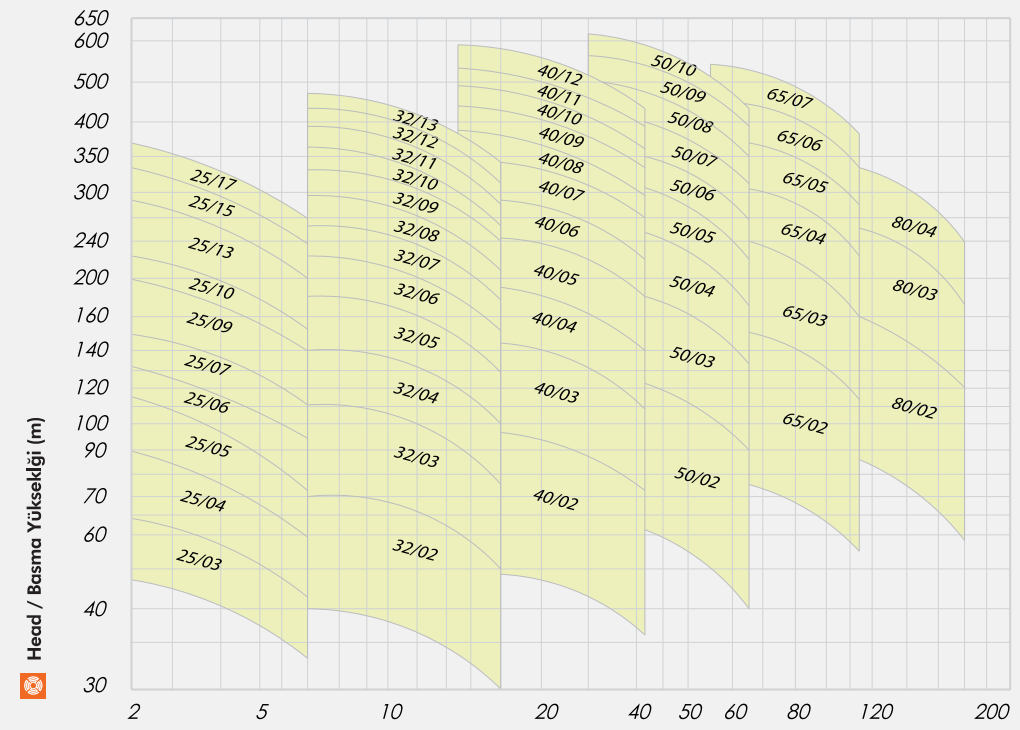

Capacity / Debi (m³/h)

For detailed curves, use our selection program.

Detay eğriler için seçim programımızı kullanınız.



## SECTIONAL VIEW

## KESİT RESİM

## ARS 25...65

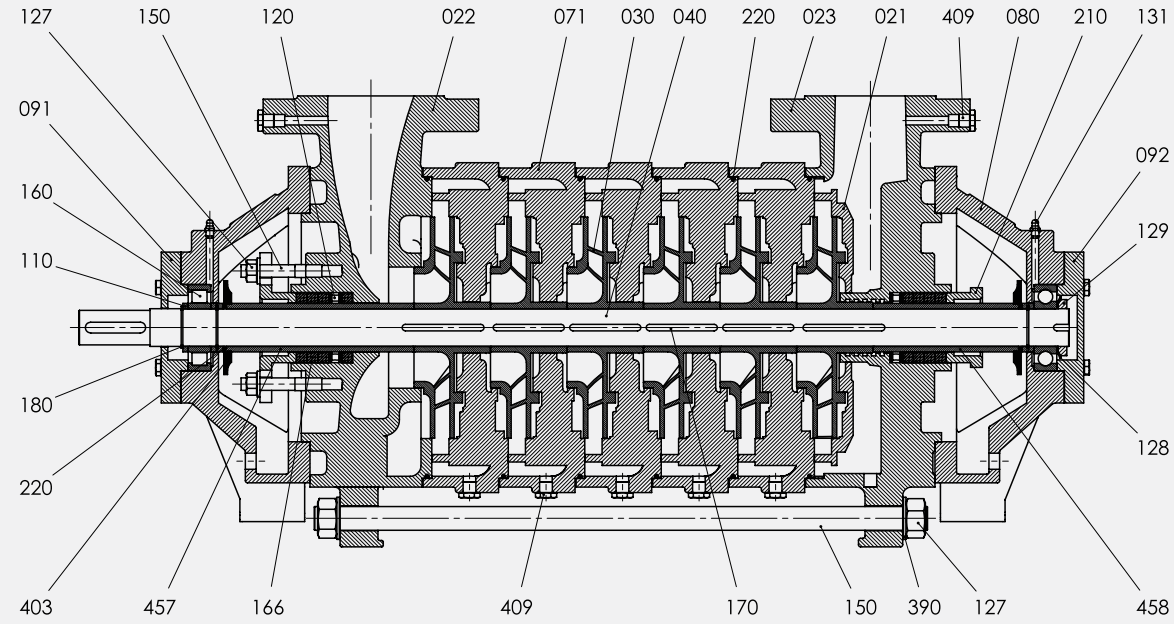

## Part List

## Parça Listesi

Discharge Diffuser	021	Basma Difüzörü
Suction Body	022	Emme Gövdesi
Discharge Body	023	Basma Gövdesi
Impeller	030	Çark
Shaft	040	Mil
Stage Body	071	Kademe Gövdesi
Bearing Housing	080	Rulman Yatağı
Bearing Cover (Coupling)	091	Rulman Kapağı (Kaplin)
Bearing Cover (Outside)	092	Rulman Kapağı (Dış)
Bearing Setting Sleeve	110	Rulman Mesafe Burcu
Flushing Ring	120	Sulama Halkası
Nut	127	Somun
Protection Sheet	128	Emniyet Sacı
Nut	129	Somun
Grease Nipple	131	Gresörlük
Casing Tiebolt	150	Saplama
Bearing	160	Rulman
Soft Packing	166	Yumuşak Salmastra
Pin	170	Kama
Ring	180	Segman
Connection Support	210	Salmastra Baskısı
O-Ring	220	O-Ring
Washer	390	Rondela
Throw Protection	403	Su Sıçratma Diski
Bolt	409	Cıvata
Seal Sleeve (Suction)	457	Salmastra Burcu (Emme)
Seal Sleeve (Discharge)	458	Salmastra Burcu (Basma)

## SECTIONAL VIEW

## KESİT RESİM

## ARS 80...200

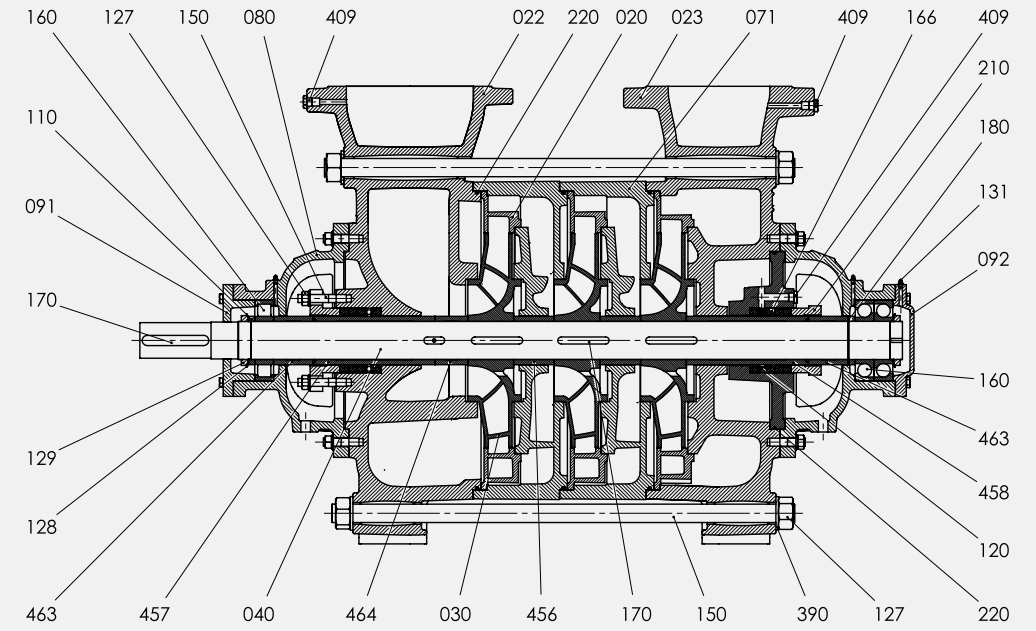

## Part List

## Parça Listesi

Diffuser	020	Difüzör
Suction Body	022	Emme Gövdesi
Discharge Body	023	Basma Gövdesi
Impeller	030	Çark
Shaft	040	Mil
Stage Body	071	Kademe Gövdesi
Bearing Housing	080	Rulman Yatağı
Bearing Cover (Coupling)	091	Rulman Kapağı (Kaplin)
Bearing Cover (Outside)	092	Rulman Kapağı (Dış)
Bearing Setting Sleeve	110	Rulman Mesafe Burcu
Flushing Ring	120	Sulama Halkası
Nut	127	Somun
Protection Sheet	128	Emniyet Sacı
Nut	129	Somun
Grease Nipple	131	Gresörlük
Casing Tiebolt	150	Saplama
Bearing	160	Rulman
Soft Packing	166	Yumuşak Salmastra
Pin	170	Kama
Ring	180	Segman
Connection Support	210	Salmastra Baskısı
O-Ring	220	O-Ring
Washer	390	Rondela
Bolt	409	Cıvata
Impeller Stage Sleeve	456	Çark Kademe Burcu
Seal Sleeve (Suction)	457	Salmastra Burcu (Emme)
Seal Sleeve (Discharge)	458	Salmastra Burcu (Basma)
Setting Sleeve (Suction & Discharge)	463	Mesafe Burcu Emme & Basma
Impeller Setting Sleeve	464	Çark Mesafe Burcu





## SECTIONAL VIEW

ARS

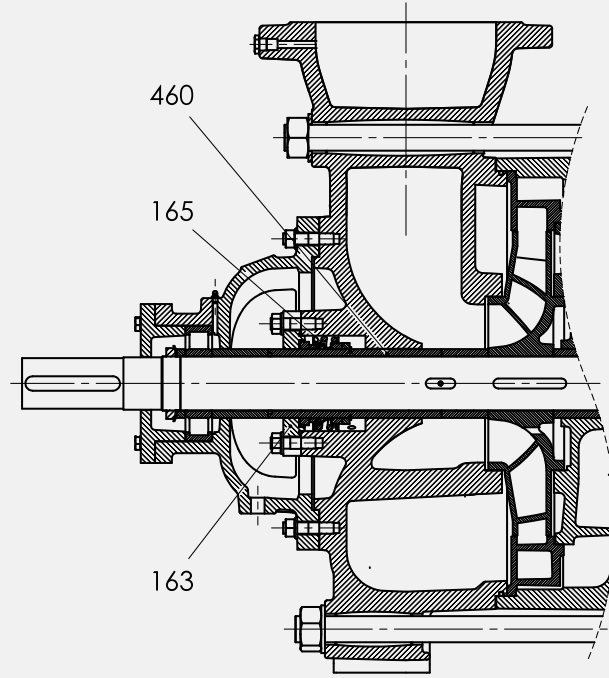

Mechanical Seal Application  
Mekanik Salmastra Uygulamas

Part List

Part Name	Part Number	Part Name
Mechanical Seal Cover	163	Mekanik Salmastra Kapağı
Mechanical Seal	165	Mekanik Salmastra
Seal Sleeve	460	Salmastra Burcu

Parça Listesi

## KESİT RESİM

## PUMP DIMENSIONS

## POMPA ÖLÇÜLERİ

ARS

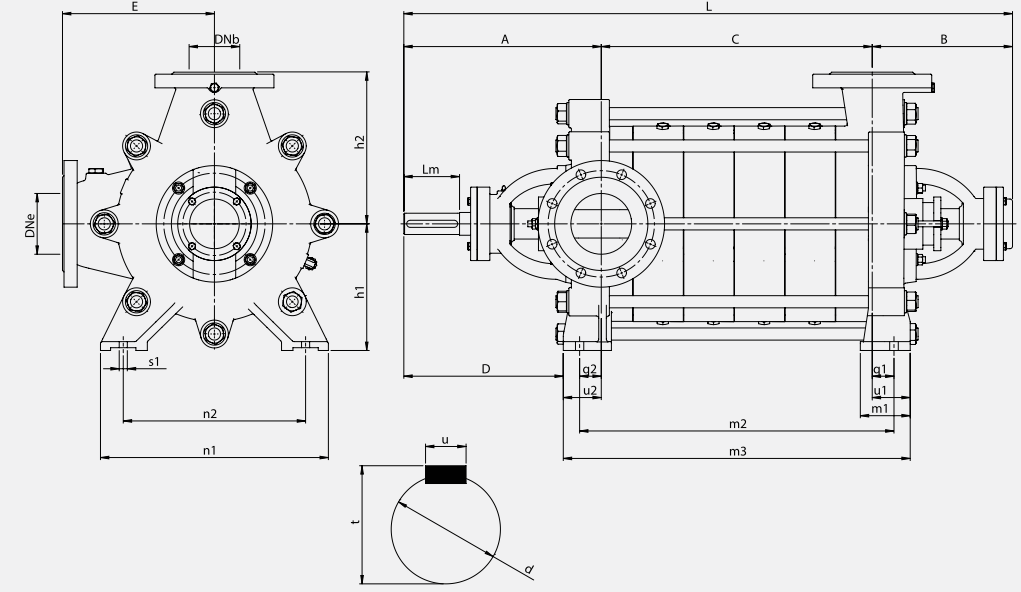

Pump Type Pompa Tipi	Dimensions / Ölçüler (mm)																	Shaft Dimensions Mil Ölçüleri				Weight Ağırlık (kg)			
	DNe	DNb	A	B	D	E	L	h1	h2	q1	q2	u1	u2	m1	m2	m3	n1	n2	s1	d	Lm	t	u	G	g
25	32	25	238	169	141	135	C+407	112	135	77	77	98	98	65	C+140	C+196	177	120	14	24	60	27	8	28	6
32	40	32	242	161	131	152	C+403	132	152	80	87	102	108	60	C+147	C+210	193	135	16	24	60	27	8	38	8
40	50	40	239	164	130	175	C+403	160	175	87	87	109	109	62	C+151	C+218	228	174	16	24	60	27	8	56	9
50	65	50	254	175	141	190	C+429	160	190	95	91	117	113	60	C+185	C+230	255	198	16	28	65	31	8	74	13
65	80	65	271	198	150	215	C+469	180	215	100	97	124	121	60	C+200	C+245	298	241	16	32	65	35	10	93	18
80	100	80	323	245	258	265	C+568	210	265	41	40	62	60	90	C+74	C+122	415	340	16	38	80	41	10	114	25
100	125	100	390	277	320	300	C+667	250	300	43	43	75	75	100	C+91	C+150	450	360	16	42	110	45	12	158	40
125	150	125	414	300	317	375	C+714	300	375	51	56	83	88	110	C+97	C+171	565	455	20	48	110	51,5	14	290	70
150	200	150	485	358	384	425	C+843	350	425	59	60	101	101	140	C+108	C+202	663	545	22	55	110	59	16	466	112
200	250	200	531	384	431	500	C+915	400	500	50	50	100	100	133	C+85	C+200	673	550	28	70	140	74,5	20	645	180
250	300	250	691	484	560	627	C+1175	500	627	75	75	131	131	156	C+135	C+262	775	625	33	100	210	106	28	950	300

Weight Calculation / Ağırlık Hesaplama:  $G + (s \cdot g)$  (s: Number of Stage / Kademe Sayısı)

Pump Type Pompa Tipi	"C" Dimensions By Stage (mm) / Kademe Sayısına Göre "C" Ölçüsü																
	2	3	4	5	6	7	8	9	10	11	12	13	14	15	16	17	
25	107	146	185	224	263	302	341	380	419	458	497	536	575	614	653	692	
32	112	155	198	241	284	327	370	413	456	499	542	585	628				
40	133	188	243	298	353	408	463	518	573	628	683	738					
50	152	214	276	338	400	462	524	586	648	710	772						
65	180	251	322	393	464	535	606										
80	198	281	364	447	530	613	696										
100	235	335	435	535	635	735											
125	279	394	509	624	739												
150	369	514															
200	438	608															
250	518	720	922														



## SECTIONAL VIEW

## KESİT RESİMİ

### ARS-DD 65...150

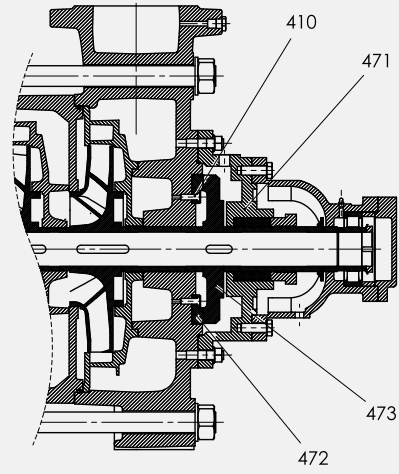

### Part List

Bolt	410	Cıvata
Disc Body	471	Disk Gövdesi
Disc (Stable)	472	Disk (Sabit)
Disc	473	Disk

### Parça Listesi

### ARS-DD 200

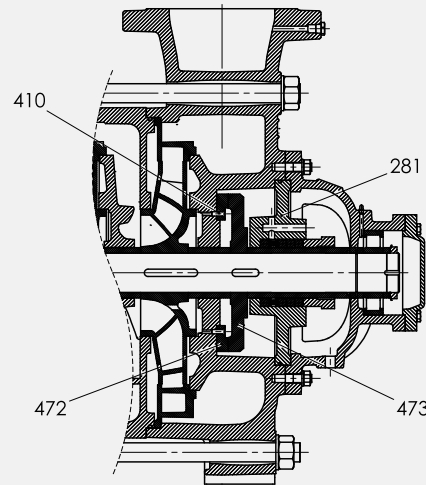

### Part List

Seal Box	281	Salmastra Kutusu
Bolt	410	Cıvata
Disc (Stable)	472	Disk (Sabit)
Disc	473	Disk

### Parça Listesi

## PUMP DIMENSIONS

## POMPA ÖLÇÜLERİ

### ARS-DD

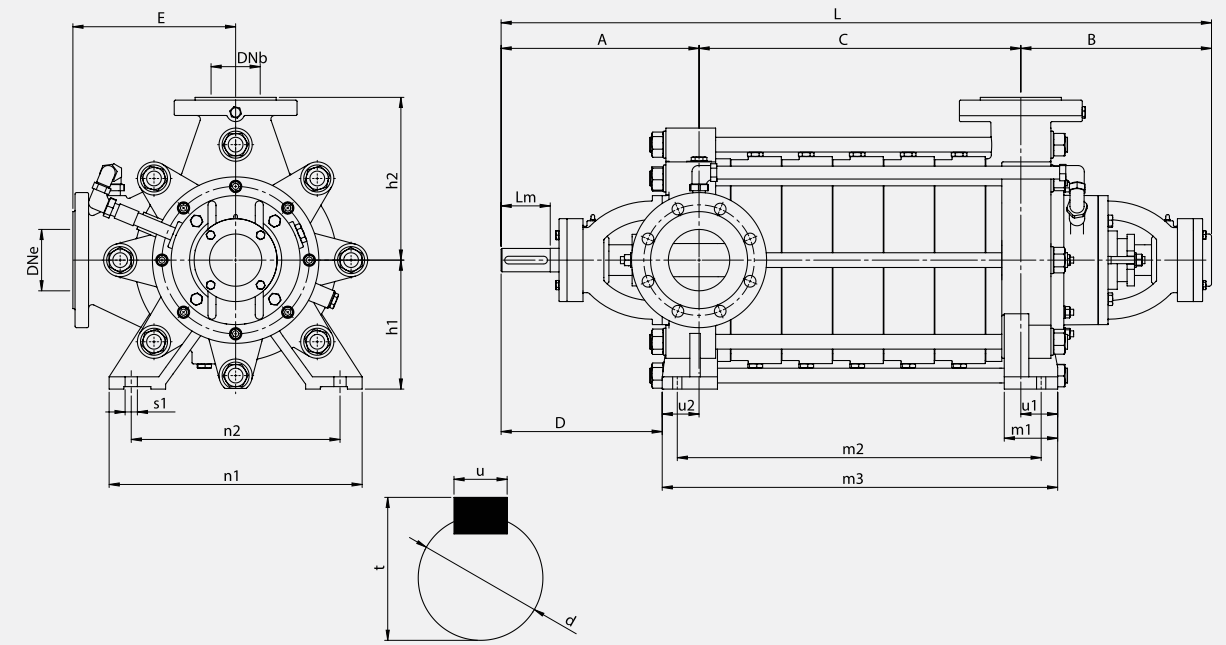

Pump Type Pompa Tipi	Dimensions / Ölçüler (mm)																Shaft Dimensions Mil Ölçüleri				
	DNe	DNb	A	B	D	E	L	h1	h2	u1	u2	m1	m2	m3	n1	n2	s1	d	Lm	t	u
65	80	65	271	269	150	215	C+540	180	215	195	120	60	C+270	C+315	300	241	16	32	66	35	10
80	100	80	323	311	262	265	C+634	210	265	60	60	87	C+313	C+120	415	340	20	38	80	41	10
100	125	100	383	361	308	300	C+744	250	300	80	75	93	C+90	C+155	450	360	16	42	110	45	12
125	150	125	414	384	326	375	C+798	300	375	85	88	110	C+136	C+173	565	455	20	48	110	51,5	14
150	200	150	485	455	384	425	C+940	350	425	101	101	140	C+120	C+202	663	545	22	55	110	59	16
200	250	200	531	384	431	500	C+915	400	500	100	100	133	C+100	C+200	675	550	28	70	140	74,5	20

Pump Type Pompa Tipi	"C" Dimensions By Stage (mm) / Kademe Sayısına Göre "C" Ölçüsü																
	1	2	3	4	5	6	7	8	9	10	11	12	13	14	15	16	17
65					393	464	535	606	677	748	819						
80					441	524	607	690	773	856	939	1022	1105	1188			
100								835	935	1035	1135	1235	1335	1435	1535		
125								854	969	1084	1199	1314	1429				
150				656	801	946	1091	1236	1381	1526							
200				778	948	1118											



## SECTIONAL VIEW

## KESİT RESİM

### ARS-U

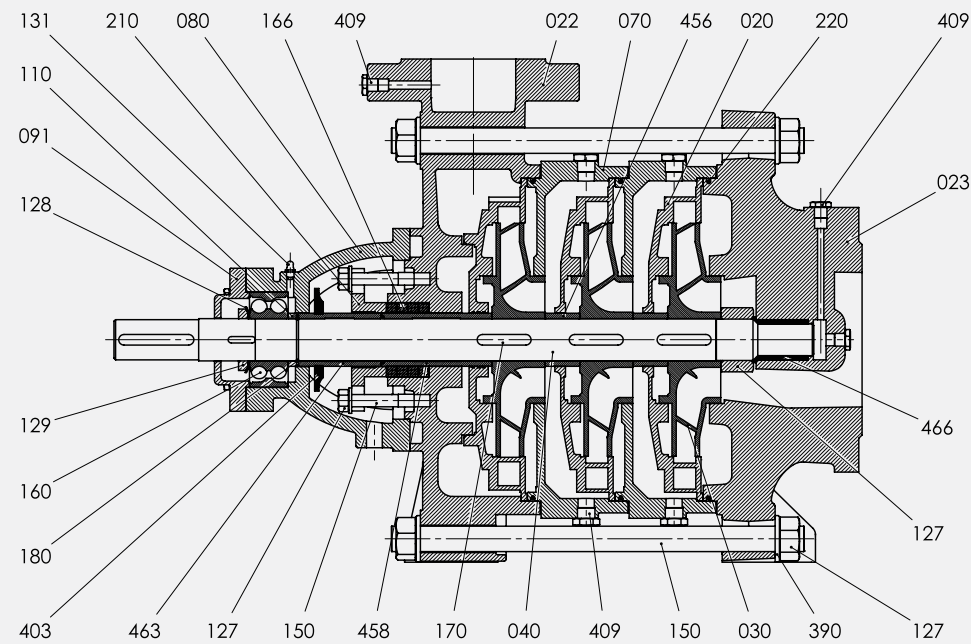

### Part List

### Parça Listesi

Part Name	Part Number	Part Name
Diffuser	020	Difüzör
Suction Body	023	Emme Gövdesi
Discharge Body	022	Basma Gövdesi
Impeller	030	Çark
Shaft	040	Mil
Stage Body	070	Kademe Gövdesi
Bearing Housing	080	Rulman Yatağı
Bearing Cover (Coupling)	091	Rulman Kapağı (Kaplin)
Bearing Setting Sleeve	110	Rulman Mesafe Burcu
Nut	127	Çektirme Somunu
Protection Sheet	128	Emniyet Sacı
Nut	129	Somun
Grease Nipple	131	Gresörlük
Casing Tiebolt	150	Saplama
Bearing	160	Rulman
Soft Packing	166	Yumuşak Salmastra
Pin	170	Kama
Ring	180	Segman
Connection Support	210	Salmastra Baskısı
O-Ring	220	O-Ring
Washer	390	Rondela
Throw Protection	403	Su Sıçratma Diski
Bolt	409	BSP Cıvata
Impeller Stage Sleeve	456	Çark Kademe Burcu
Seal Sleeve (Discharge)	458	Salmastra Burcu (Basma)
Setting Sleeve (Suction & Discharge)	463	Mesafe Burcu (Emme&Basma)
Suction Housing	466	Emme Yatağı

## PUMP DIMENSIONS

## POMPA ÖLÇÜLERİ

### ARS-U

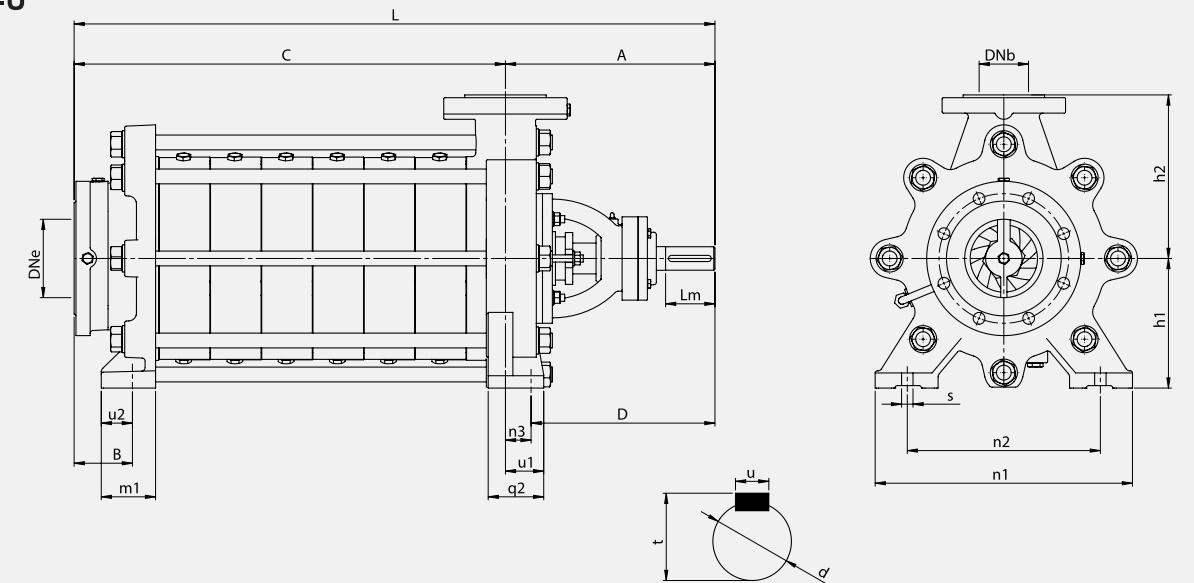

Pump Type Pompa Tipi	Dimensions / Ölçüler (mm)														Shaft Dimensions Mil Ölçüleri				Weight Ağırlık (kg)		
	DNe	DNb	A	B	D	L	h1	h2	q2	u1	u2	m1	n1	n2	s	d	Lm	t	u	G	g
40	65	40	239	25	130	C+239	160	175	87	109	22	77	236	177	16	24	60	27	8	58	10
50	80	50	258	27	163	C+258	160	190	60	117	24	87	260	203	16	28	65	31	8	89	13
65	100	65	273	34	170	C+273	180	215	60	125	24	91	298	244	16	32	65	35	10	92	20
80	125	80	340	72	298	C+340	210	265	90	62	28	88	413	340	16	38	80	37	10	128	26
100	150	100	390	100	320	C+390	250	300	90	65	32	100	450	360	16	42	110	45	12	177	42
125	200	125	414	73	317	C+414	300	375	110	80	34	110	565	455	20	48	110	51,5	14	330	76
150	200	150	485	62	384	C+485	350	425	130	105	34	135	663	545	22	55	110	59	16	580	121

Weight Calculation / Ağırlık Hesaplama:  $G+(s \cdot g)$  (s: Number of Stage / Kademe Sayısı)

Pump Type Pompa Tipi	"C" Dimensions By Stage (mm) / Kademe Sayısına Göre "C" Ölçüsü												
	2	3	4	5	6	7	8	9	10	11	12	13	
40	187	242	297	352	407	462	517	572	627	682	737	792	
50	212	274	336	398	460	522	584	646	708	770	832		
65	247	318	389	460	531	602	673	744	815	886			
80	287	367	450	533	616	699	782	865	948	1031			
100	347	447	547	647	747	847	947	1047					
125	364	479	594	709	824	939							
150	437	582	727	872									



## SECTIONAL VIEW

## KESİT RESİM

### ARS-KC

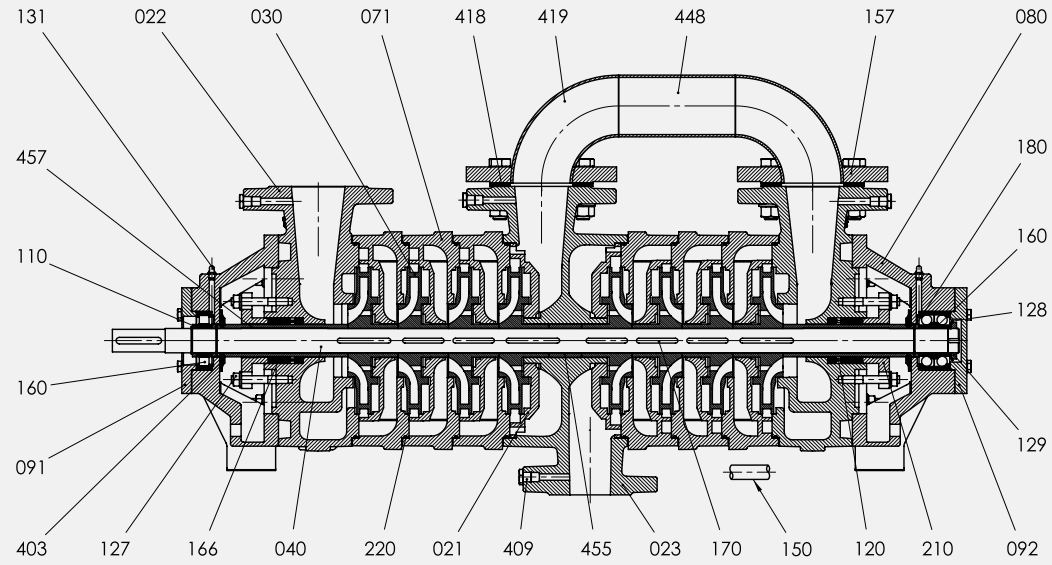

### Part List

### Parça Listesi

Part Name	Part No	Part Name	Part No
Discharge Diffuser	021	Basma Difüzörü	021
Suction Body	022	Emme Gövdesi	022
Discharge Body	023	Basma Gövdesi	023
Impeller	030	Çark	030
Shaft	040	Mil	040
Stage Body	071	Kademe Gövdesi	071
Bearing Housing	080	Rulman Yatağı	080
Bearing Cover (Coupling)	091	Rulman Kapağı (Kaplin)	091
Bearing Cover (Outside)	092	Rulman Kapağı (Dış)	092
Bearing Setting Sleeve	110	Rulman Mesafe Burcu	110
Flushing Ring	120	Sulama Halkası	120
Nut	127	Somun	127
Protection Sheet	128	Emniyet Sacı	128
Nut	129	Somun	129
Grease Nipple	131	Gresörlük	131
Casing Tiebolt	150	Saplama	150
Flange	157	Flanş	157
Bearing	160	Rulman	160
Soft Packing	166	Yumuşak Salmastra	166
Pin	170	Kama	170
Ring	180	Segman	180
Connection Support	210	Salmastra Baskısı	210
O-Ring	220	O-Ring	220
Throw Protection	403	Su Sıçratma Diski	403
Bolt	409	Cvata	409
Flange Gasket	418	Flanş Contası	418
Elbow	419	Dirsek	419
Connection Pipe	448	Birleştirme Borusu	448
Discharge Centering Sleeve	455	Basma Merkezleme Burcu	455
Seal Sleeve (Suction)	457	Salmastra Burcu (Emme)	457

## PUMP DIMENSIONS

## POMPA ÖLÇÜLERİ

### ARS-KC

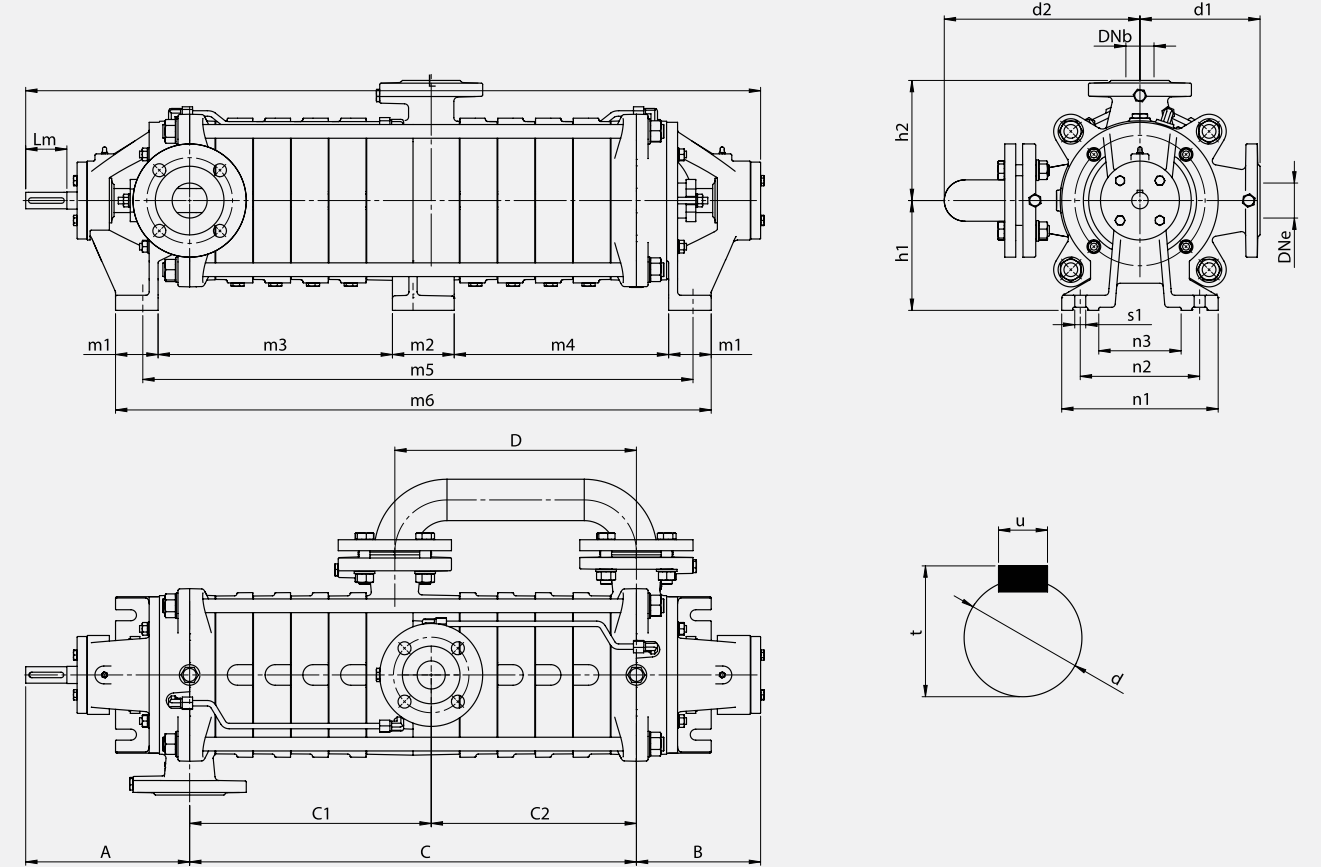

Pump Type Pompa Tipi	Dimensions / Ölçüler (mm)																							Shaft Dimensions Mil Ölçüleri				
	DN <sub>e</sub>	DN <sub>b</sub>	A	B	D	d1	d2	L	C1	C2	C	h1	h2	H	m1	m2	m3	m4	m5	m6	n1	n2	n3	s1	d	Lm	t	u
40-10	50	40	239	181	352	175	286	1071	352	299	651	160	175	335	62	90	342	312	824	869	228	174	120	16	24	60	27	8
40-12	50	40	239	181	407	175	286	1181	407	354	761	160	175	335	62	90	397	369	934	979	228	174	120	16	24	60	27	8
40-14	50	40	239	181	462	175	286	1291	462	409	871	160	175	335	62	90	452	422	1044	1088	228	174	120	16	24	60	27	8

Pump Type Pompa Tipi	Dimensions / Ölçüler (mm)																							Shaft Dimensions Mil Ölçüleri				
	DN <sub>e</sub>	DN <sub>b</sub>	A	B	D	d1	d2	L	C1	C2	C	h1	h2	H	m1	m2	m3	m4	m5	m6	n1	n2	n3	s1	d	Lm	t	u
50-08	65	50	254	190	334	190	327	1053	275	274	609	160	190	350	60	100	327	287	790	834	255	198	140	16	28	65	31	8
50-10	65	50	254	190	396	190	327	1177	337	336	733	160	190	350	60	100	389	349	914	958	255	198	140	16	28	65	31	8
50-12	65	50	254	190	458	190	327	1301	399	398	857	160	190	350	60	100	451	411	1038	1082	255	198	140	16	28	65	31	8





Bearing Type / Rulman Tipi 1500-1800 rpm / (d/d)			
Pump Type / Pompa Tipi	Stage Number / Kademe Sayısı	Bearing Type / Rulman Tipi	
		S / E	D / B
ARS 32	2...14	NU 305	6305
ARS 40	2...13	NU 305	6305
ARS 50	2...12	NU 306	6306
ARS 65	2...8	NU 307	6307
ARS 80	2...8	NU 308	3308
ARS 100	2...7	NU 309	3309
ARS 125	2...6	NU 310	3310
ARS 150	2...3	NU 312	3312
ARS 200	2...3	NU 315	2x7315
ARS 250	2...4	NU 321	2x7321

Bearing Type / Rulman Tipi 1500-1800 rpm / (d/d)			
Pump Type / Pompa Tipi	Stage Number / Kademe Sayısı	Bearing Type / Rulman Tipi	
		S / E	D / B
ARS-DD 65	9...11	NU 307	NU 307
ARS-DD 80	9...14	NU 308	NU 308
ARS-DD 100	8...15	NU 309	NU 309
ARS-DD 125	7...12	NU 310	NU 310
ARS-DD 150	4...10	NU 312	NU 312
ARS-DD 200	4...6	NU 315	NU 315

Bearing Type / Rulman Tipi 1500-1800 rpm / (d/d)			
Pump Type / Pompa Tipi	Stage Number / Kademe Sayısı	Bearing Type / Rulman Tipi	
		S / E	D / B
ARS-U 40	2...13	-	6305
ARS-U 50	2...12	-	6306
ARS-U 65	2...8	-	6307
ARS-U 80	2...8	-	6308
ARS-U 100	2...7	-	3309
ARS-U 125	2...6	-	3310
ARS-U 150	2...3	-	3312

Bearing Type / Rulman Tipi 3000-3600 rpm / (d/d)			
Pump Type / Pompa Tipi	Stage Number / Kademe Sayısı	Bearing Type / Rulman Tipi	
		S / E	D / B
ARS-KC 40	10...14	NU 305	2x7305
ARS-KC 50	8...12	NU 306	2x7306
ARS-KC 65	6...10	NU 307	2x7307

Bearing Type / Rulman Tipi 3000-3600 rpm / (d/d)			
Pump Type / Pompa Tipi	Stage Number / Kademe Sayısı	Bearing Type / Rulman Tipi	
		S / E	D / B
ARS 25	2...17	NU 305	6305
ARS 32	2...9	NU 305	6305
ARS 32	10...13	NU 305	6405
ARS 40	2...6	NU 305	6305
ARS 40	7...9	NU 305	6405
ARS 50	2...5	NU 306	6306
ARS 50	6...7	NU 306	6406
ARS 65	2...4	NU 307	6307
ARS 80	2...4	NU 308	3308

Bearing Type / Rulman Tipi 3000-3600 rpm / (d/d)			
Pump Type / Pompa Tipi	Stage Number / Kademe Sayısı	Bearing Type / Rulman Tipi	
		S / E	D / B
ARS-DD 65	5...10	NU 307	NU 307
ARS-DD 80	5...8	NU 308	NU 308

Bearing Type / Rulman Tipi 3000-3600 rpm / (d/d)			
Pump Type / Pompa Tipi	Stage Number / Kademe Sayısı	Bearing Type / Rulman Tipi	
		S / E	D / B
ARS-U 40	2...6	-	6305
ARS-U 50	2...5	-	6306
ARS-U 65	2...4	-	6307
ARS-U 80	2...4	-	3308

○ Suction / Emme: E  
 Discharge / Basma: B



## FLANGE DIMENSIONS

Pump Type Pompa Tipi	Suction & Discharge / Emme & Basma (PN 16)				Suction & Discharge / Emme & Basma (PN 40)			
	Df	k	s	n	Df	k	s	n
25	115	85	16	4	115	85	16	4
32	140	100	19	4	140	100	19	4
40	150	110	19	4	150	110	19	4
50	165	125	19	4	165	125	19	4
65	185	145	19	4	185	145	19	8
80	200	160	19	8	200	160	19	8
100	220	180	19	8	235	190	23	8
125	250	210	19	8	270	220	28	8
150	285	240	23	8	300	250	28	8
200	340	295	23	12	375	320	31	12
250	405	355	23	12	450	385	34	12
300	460	410	23	12	515	450	34	16

○ TS EN 1092-2 ○ "n" Number of Holes / Delik Sayısı

## FLANŞ ÖLÇÜLERİ

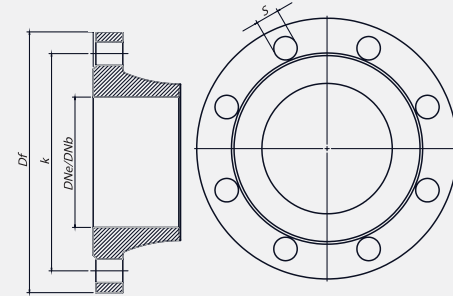

## FLANGE POSITIONS

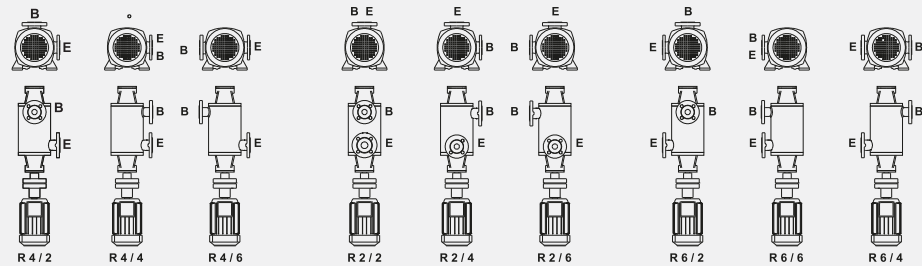

○ Clockwise rotation viewed from driver  
(Suction flange is on the motor side)

Motor tarafından bakıldığında saat yönünde  
(Emme flanşı motor tarafında)

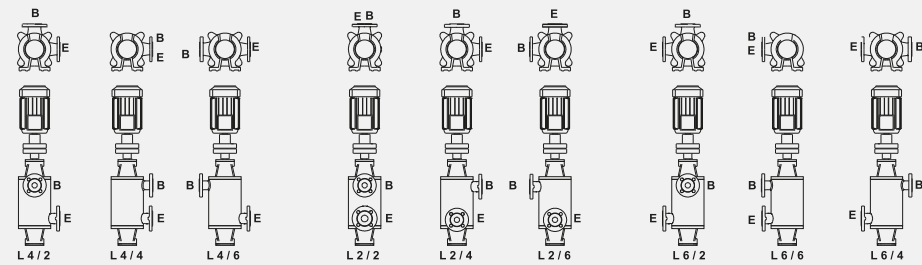

○ Counter clockwise rotation viewed from driver  
(Discharge flange is on the motor side)

Motor tarafından bakıldığında saatin tersi yönünde  
(Basma flanşı motor tarafında)



○ Direction of rotation viewed from driver end. / Motor tarafından bakıldığında dönme yönü.

R : Right / Sağ  
L : Left / Sol

## FLANŞ KONUMLARI

**48 YIL**  
**48 Years**

48 Yıldır Yanınızdayız  
We Have Been With You For 48 Years

**DENEY**  
**Testing**

Her Ürün İle Test Raporu Teslimi  
Supply Testing Report For Each Pump

**Sfero Döküm**  
Ductile Cast Iron

**Çelik**  
Steel

**Bronz**  
Bronze

**Pik Döküm**  
Cast Iron

**Paslanmaz Çelik**  
Stainless Steel

**Duplex Çelik**  
Duplex Steel

**KALITE KONTROL**  
**Quality Control**

**İŞLEME**  
**Machining**

CNC - Hassas İşleme - Kalite Kontrol  
CNC - Sensitive Machining - Quality Control

**STOK**  
**Stock**

500.000 Kg İşlenmiş Parça  
500.000 Kg Machined Part

**DÖKÜM**  
**Casting**

**I'M**  
**TECH**  
NOLOGY





DPT SERIES

TKF SERIES

ARS SERIES

**ARS SERIES**

TKF-M SERIES

SP SERIES

TKF-KE SERIES

**STORE / MAĞAZA:**

Fevzi Çakmak Mh. 10644 Sk. No:43-45 Karatay / Konya / Türkiye

Tel: +90.332 237 03 31 Fax: +90.332 235 43 64

Mail: info2@sempapompa.com

**FACTORY / FABRİKA:**

Büyük Kayaak Mh. K.O.S.B. Kuddusi Cd. 22. Sk. No:4 Selçuklu / Konya / Türkiye

Tel: +90.332 345 32 90 Fax: +90.332 345 32 95

Mail: info@sempapompa.com